



9.2 - 9.5 EER, PACKAGE HEAT PUMP, 7.0 to 14.0 kw, 2 - 4 TONS

3-Phase, 400-3-50

REFRIGERATION CIRCUIT

- Environmentally sound R-410A refrigerant
- Scroll compressors standard on all models
- Copper tube/aluminum fin condenser and evaporator coils
- Liquid filter driers for clean, unrestricted operation

EASY TO INSTALL AND SERVICE

- Installs easily on a rooftop or at ground level
- Easy three-panel accessibility for maintenance and installation
- Converts to down discharge applications

BUILT TO LAST

- Louvered grille
- Pre-painted steel cabinet
- PSC indoor blower motor on all models
- Vertical condenser fan discharge
- Full perimeter steel base rails
- High and Low pressure switches factory installed



| UNIT PERFORMANCE DATA | | | | | | | |
|-----------------------|------------|-----------------------------|--------------------|-----|---------------------|---|---------------------------|
| Model Number | Volt-Ph-Hz | | | | Sound Ratings (dBA) | Unit Dimensions H x W x D in. (mm) | Operating Weight lbs (kg) |
| | | Nominal Capacity kw / BTU/h | Standard CFM (L/s) | EER | | | |
| PH4E24000Z000A | 400-3-50 | 6.9 / 23,400 | 800 (378) | 9.5 | 75 | 38 x 48-3/16 x 32-5/8 (965 x 1224 x 829) | 314 (142) |
| PH4E30000Z000A | 400-3-50 | 8.6 / 29,200 | 1000 (472) | 9.5 | 75 | 40 x 48-3/16 x 32-5/8 (1016 x 1224 x 829) | 335 (152) |
| PH4E36000Z000A | 400-3-50 | 10.7 / 36,700 | 1200 (567) | 9.5 | 75 | 40 x 48-3/16 x 32-5/8 (1016 x 1224 x 829) | 343 (156) |
| PH4E48000Z000A | 400-3-50 | 14.4 / 49,300 | 1600 (756) | 9.2 | 78 | 44 x 48-3/16 x 44-1/8 (1118 x 1224 x 1122) | 373 (169) |

TABLE OF CONTENTS

| | |
|---------------------------------|----|
| FEATURES | 1 |
| MODEL NUMBER NOMENCLATURE | 2 |
| ARI CAPACITIES | 3 |
| PHYSICAL DATA | 4 |
| ACCESSORIES | 5 |
| BASE UNIT DIMENSIONS | 6 |
| ACCESSORY ROOF CURB | 8 |
| SELECTION PROCEDURE | 9 |
| PERFORMANCE DATA | 10 |
| TYPICAL PIPING AND WIRING | 21 |
| APPLICATION DATA | 22 |
| ELECTRICAL DATA | 24 |
| TYPICAL WIRING SCHEMATICS | 25 |
| CONTROLS | 26 |
| GUIDE SPECIFICATIONS | 27 |

MODEL NUMBER NOMENCLATURE

| MODEL NOMENCLATURE | | | | | | | | | | |
|-----------------------------|----------|----------|----------|----------|-----------|------------|-----------------------------|----------------------------------|----------|----------|
| MODEL SERIES | P | H | 4 | E | 24 | 000 | Z | 000 | A | 1 |
| P = Package | | | | | | | | | | |
| H = Heat Pump | | | | | | | | | | |
| 4 = R-410A | | | | | | | | | | |
| E = Series | | | | | | | | | | |
| 24 = 24,000 BTUH = 2 Tons | | | | | | | | | | |
| 30 = 30,000 BTUH = 2.5 Tons | | | | | | | | | | |
| 36 = 36,000 BTUH = 3 Tons | | | | | | | | | | |
| 48 = 48,000 BTUH = 4 Tons | | | | | | | | | | |
| NOMINAL COOLING BTUH | | | | | | | | | | |
| 000 = N/A | | | | | | | NOMINAL HEATING BTUH | | | |
| Z = 400-3-50 | | | | | | | VOLTAGE | | | |
| 000 = N/A | | | | | | | | FACTORY INSTALLED OPTIONS | | |
| Sales Model Digit | | | | | | | | | | |
| Engineering Digit | | | | | | | | | | |

Cooling Capacities and Efficiencies

| PH4E | NET COOLING CAPACITIES (kW) | STANDARD CFM/ L/s | NET COOLING CAPACITY (Btuh) | EER | kW |
|------|-----------------------------|-------------------|-----------------------------|-----|------|
| 24 | 6.9 | 800/378 | 23400 | 9.5 | 6.9 |
| 30 | 8.6 | 1000/472 | 29200 | 9.5 | 8.6 |
| 36 | 10.7 | 1200/567 | 36700 | 9.5 | 10.7 |
| 48 | 14.4 | 1600/756 | 49300 | 9.2 | 14.4 |

Heating Capacities and Efficiencies

| PH4E | HIGH HEAT CAPACITY (BTUH) @ 47°F/8.3°C | HIGH HEAT COP @ 47°F/8.3°C | LOW HEAT CAPACITY (BTUH) @ 17°F/-8.3°C | LOW HEAT COP @ 17°F/-8.3°C |
|------|--|----------------------------|--|----------------------------|
| 24 | 23,800 | 3.0 | 13,000 | 2.0 |
| 30 | 28,200 | 3.1 | 15,600 | 2.0 |
| 36 | 34,400 | 3.2 | 18,000 | 2.0 |
| 48 | 44,000 | 3.1 | 23,600 | 2.0 |

LEGEND

Kw – Kilowatt

dB–Sound Levels (decibels)

db–Dry Bulb

EER – Energy Efficiency Ratio

wb–Wet Bulb

COP – Coefficient of Performance

Notes:

1. Ratings are net values, reflecting the effects of circulating fan heat.

Ratings are based on:

Cooling Standard: 80°F (26.7°C) db, 67°Fwb (19.4°C) indoor entering–air temperature and 95°F db (35°C) outdoor entering–air temperature.

2. Before purchasing this appliance, read important energy cost and efficiency information available from your retailer.

A-WEIGHTED SOUND POWER LEVEL (dBA)

| MODEL PH4E | STANDARD RATING | TYPICAL OCTAVE BAND SPECTRUM (dBA) (without tone adjustment) | | | | | | |
|------------|-----------------|--|------|------|------|------|------|------|
| | | 125 | 250 | 500 | 1000 | 2000 | 4000 | 8000 |
| 24 | 75 | 60.4 | 58.3 | 64.8 | 66.9 | 64.3 | 59.8 | 51.8 |
| 30 | 75 | 58.2 | 59.2 | 65.8 | 67.7 | 64.8 | 61.8 | 53.6 |
| 36 | 75 | 60.4 | 61.6 | 66.9 | 67.8 | 64.6 | 60.7 | 52.8 |
| 48 | 78 | 65.2 | 69.7 | 72.7 | 72.9 | 69.8 | 65.8 | 57.9 |

NOTE: Tested in accordance with ARI Standard 270 (not listed in ARI).

PHYSICAL DATA

| UNIT SIZE | PH4E24 | PH4E30 | PH4E36 | PH4E48 |
|--|-------------------|------------|------------|------------|
| NOMINAL CAPACITY (ton) | 2 | 2.5 | 3 | 4 |
| (kW) | 7 | 8.8 | 10.6 | 14.1 |
| OPERATING WEIGHT (lb) | 314 | 335 | 343 | 373 |
| (kg) | 142.4 | 152.0 | 155.6 | 169.2 |
| COMPRESSOR QUANTITY | 1 | | | |
| TYPE | SCROLL COMPRESSOR | | | |
| REFRIGERANT | R-410A | | | |
| METERING DEVICE ID | Accurater | | | |
| Refrigerant (R-410A) Quantity (lb) | 6.9 | 9.6 | 10.0 | 12.0 |
| Quantity (kg) | 3.2 | 4.0 | 4.2 | 4.8 |
| ORIFICE ID (in.) | 0.059 | 0.061 | 0.067 | 0.078 |
| (mm) | 1.55 | 1.55 | 1.70 | 1.93 |
| ORIFICE OD (in.) | 0.032 (2) | 0.040 (2) | 0.040 (2) | 0.046 (2) |
| (mm) | .81 | 1.02 | 1.02 | 1.17 |
| OUTDOOR COIL | | | | |
| Rows... Fins/in. | 2...17 | 2...17 | 2...17 | 2...17 |
| Rows... Fins (cm) | 2...6.7 | 2...6.7 | 2...6.7 | 2...6.7 |
| face area (sq. ft.) | 8.5 | 10.3 | 10.3 | 13.5 |
| face area (sq. m) | .79 | .96 | .96 | 1.25 |
| OUTDOOR FAN | | | | |
| Nominal Airflow (CFM) | 2200 | 2200 | 2200 | 2400 |
| Nominal Airflow (L/s) | 1038 | 1038 | 1038 | 1133 |
| Diameter (in.) | 22 | 22 | 22 | 22 |
| Diameter (mm) | 559 | 559 | 559 | 559 |
| Motor HP (RPM) | 1/4 (900) | 1/4 (900) | 1/4 (900) | 1/3 (1340) |
| Motor kW | 187 | 187 | 187 | 249 |
| Motor (r/s) | .187...15 | .187...15 | .187...15 | .249...22 |
| INDOOR COIL | | | | |
| Rows... Fins/in. | 3...15 | 3...15 | 4...15 | 4...15 |
| Rows... Fins (cm) | 3...5.9 | 3...5.9 | 4...5.9 | 4...5.9 |
| face area (sq. ft.) | 3.7 | 3.7 | 3.7 | 4.7 |
| face area (sq. m) | .34 | .34 | .34 | .44 |
| INDOOR BLOWER | | | | |
| Nominal Cooling Airflow (CFM) | 800 | 1000 | 1200 | 1600 |
| Nominal Cooling Airflow (L/s) | 378 | 472 | 566 | 708 |
| Size (in.) | 10x10 | 10x10 | 10x10 | 11x10 |
| Size (cm) | 25.4x25.4 | 25.4x25.4 | 25.4x25.4 | 27.9x25.4 |
| Motor (HP) | 1/4 | 1/2 | 1/2 | 1.0 |
| Motor (kW) | 187 | 373 | 373 | 746 |
| HIGH-PRESSURE SWITCH (psig) | | | | |
| Cutout | 650±15 | | | |
| Reset (Auto) | 420±25 | | | |
| Cutout (kPa) | | | | |
| Reset (Auto) (kPa) | | | | |
| LOSS-OF-CHARGE/LOW-PRESSURE SWITCH (Liquid Line) (psig) Cutout Reset (Auto) | 20±5 | | | |
| Cutout (kPa) | 45±10 | | | |
| Reset (Auto) (kPa) | | | | |
| RETURN-AIR FILTERS*† | | | | |
| throwaway (in.) | 20x20x1 | 20x20x1 | 24x24x1 | 24x30x1 |
| (mm) | 508x508x25 | 508x508x25 | 610x610x25 | 610x762x25 |

*Required filter sizes shown are based on the larger of the ARI (Air conditioning and Refrigeration Institute) rated cooling airflow or the heating airflow velocity of 300 ft/minute for throwaway type or 450 ft/minute for high-capacity type. Air filter pressure drop for non-standard filters must not exceed 0.08 IN. W.C.

† If using accessory filter rack refer to the filter rack installation instructions for correct filter size and quantity.

ACCESSORIES

| ITEM | DESCRIPTION | FACTORY INSTALLED OPTION | FIELD INSTALLED ACCESSORY |
|-------------------------------------|--|--------------------------|---------------------------|
| Corporate Thermostats | Thermostats provide control for the system heating and cooling functions. | | X |
| Crankcase Heater | Crankcase Heater provides anti-floodback protection for low-load cooling applications. | | X |
| Electric Heaters | Electric Heat Supplement | | X |
| Filter Rack | Filter Rack features easy installation, serviceability, and high-filtering performance for vertical applications. Includes 1-in. filter. | | X |
| Flat Roof Curbs | Flat Roof Curbs in both 11-in (279 mm) and 14-in. (356 mm) sizes are available for roof mounted applications. | | X |
| Flat Roof Adaptor Kit | Allows units with base rails to sit on existing (old style) curbs. | | X |
| Low Ambient Kit | Low Ambient Kit (Motormaster II Control) allows the use of mechanical cooling down to outdoor temperatures as low as 0°F (-18° C) when properly installed. | | X |
| Manual Outside Air Damper | Manual Outside Air Damper includes hood and filter rack with adjustable damper blade for up to 25% outdoor air. | | X |
| Square-to-Round Duct Transition Kit | Square-to-Round Duct Transition Kit enable 24-48 size units to be fitted to 14 in (356 mm). round ductwork. | | X |

Electric Heaters

| CATALOG ORDERING NO. | NOMINAL CAPACITY (kW) | FUSED (Yes/No) | STAGES | USED WITH SIZES | | | |
|----------------------|-----------------------|----------------|--------|-----------------|----|----|----|
| | | | | 24 | 30 | 36 | 48 |
| CPHEATER076A00 | 6.5 | No | 1 | X | X | X | X |
| CPHEATER077A00 | 8.7 | No | 1 | X | X | X | X |
| CPHEATER078A00 | 13.0 | No | 1 | | X | X | X |
| CPHEATER079A00 | 17.4 | No | 1 | | | | X |

NOTE: Electric heaters are rated at 400v. Refer to Multiplication Factors table for other voltages.
X = Approved combinations.

Minimum Airflow for Safe Electric Heater Operation (CFM)

| SIZE | 24 | 30 | 36 | 48 |
|------|-----|------|------|------|
| Cfm | 800 | 1000 | 1200 | 1600 |
| L/s | 378 | 472 | 567 | 756 |

Filter Rack and Outside Air Damper

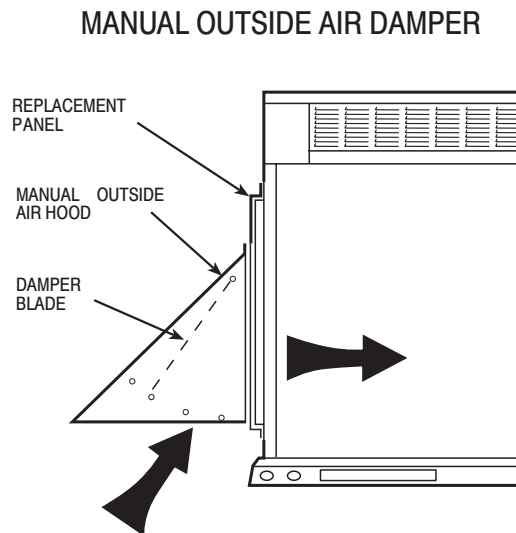
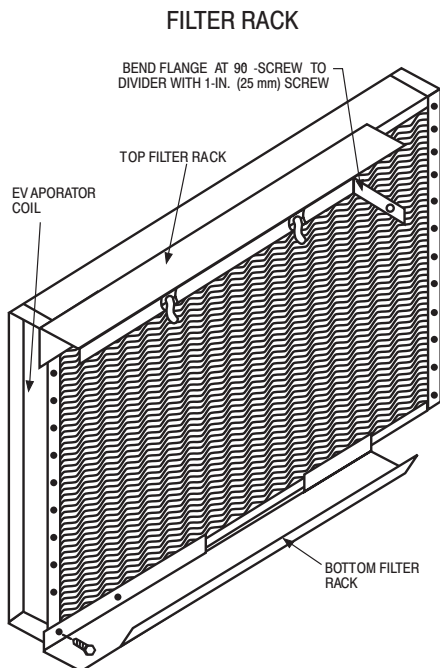

UNIT DIMENSIONS - PH4E24-36

| UNIT | ELECTRICAL CHARACTERISTICS | | UNIT WT. | | UNIT HEIGHT | | | CENTER OF GRAVITY IN/MM | | | | |
|--------|----------------------------|----------|----------|-------|-------------|------|----|-------------------------|--------|-----|--------|-----|
| | 400-3-50 | 400-3-50 | LB | KG | "A" | "K" | Z | X | Y | Z | | |
| PH4E24 | 400-3-50 | 400-3-50 | 314 | 142.4 | 38 | 965 | 19 | 483 | 18-3/8 | 464 | 16 | 406 |
| PH4E30 | 400-3-50 | 400-3-50 | 335 | 152.0 | 40 | 1016 | 20 | 508 | 19-3/8 | 489 | 17-5/8 | 447 |
| PH4E36 | 400-3-50 | 400-3-50 | 343 | 155.6 | 40 | 1016 | 20 | 508 | 19 | 483 | 18-1/2 | 419 |

| UNITS | CORNER WEIGHT LBS/KG | | | |
|--------|----------------------|-----|-----|-----|
| | "1" | "2" | "3" | "4" |
| PH4E24 | 67 | 30 | 59 | 27 |
| PH4E30 | 67 | 30 | 59 | 27 |
| PH4E36 | 68 | 31 | 60 | 28 |

REQUIRED CLEARANCES TO COMBUSTIBLE MATL.

INCHES [MM]

TOP OF UNIT: 14 [355.61]
 SIDE OF UNIT: 12 [304.81]
 SIDE OF ELECTRICAL PANEL: 6 [152.40]
 BOTTOM OF UNIT: 6 [152.40]
 ELECTRICAL PANEL: 36 [914.41]

INCHES [MM]

NEC. REQUIRED CLEARANCES.

BETWEEN UNITS, POWER ENTRY SIDE: 36 [914.41]
 UNIT AND UNGROUNDED SURFACES, POWER ENTRY SIDE: 36 [914.41]
 UNIT AND BLOCK OR CONCRETE WALLS AND OTHER GROUNDED SURFACES, POWER ENTRY SIDE: 42 [1066.81]

INCHES [MM]

REQUIRED CLEARANCE FOR OPERATION AND SERVICING

EVAP. COIL ACCESS SIDE: 36 [914.41]
 POWER ENTRY SIDE: 42 [1066.81]
 (EXCEPT FOR NEC REQUIREMENTS)
 UNIT TOP: 48 [1219.21]
 SIDE OPPOSITE DUCTS: 36 [914.41]
 DUCT PANEL: 12 [304.81]

*MINIMUM DISTANCES: IF UNIT IS PLACED LESS THAN 12 [304.81] FROM WALL SYSTEM, THEN SYSTEM PERFORMANCE MAY BE COMPROMISED.

DIMENSIONS IN [] ARE IN MILLIMETERS

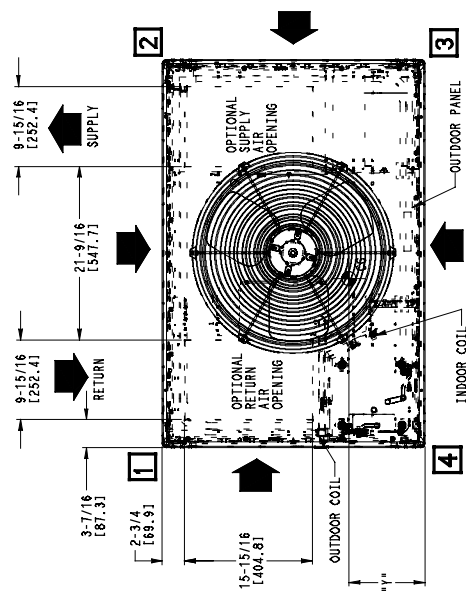

TOP VIEW

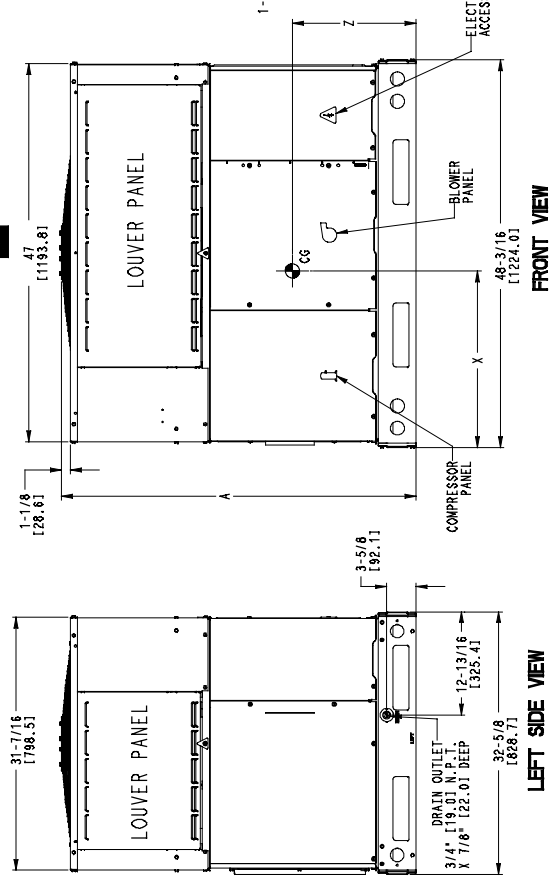

FRONT VIEW

LEFT SIDE VIEW

RIGHT SIDE VIEW

REAR VIEW

50EZ500398_REV3.0

UNIT DIMENSIONS - PH4E48

| UNIT | ELECTRICAL CHARACTERISTICS | UNIT WT. | | UNIT HEIGHT | | | | CENTER OF GRAVITY IN/MM | | | |
|--------|----------------------------|----------|-------|-------------|------|-----|-----|-------------------------|-----|----|-----|
| | | LB | KG | "A" | "B" | "C" | "D" | X | Y | Z | |
| PH4E48 | 400-3-50 | 373 | 169.2 | 44 | 1118 | 20 | 508 | 21-3/8 | 540 | 18 | 457 |

| UNITS | CORNER WEIGHT LB/KG | | | |
|--------|---------------------|-----|-----|-----|
| | "1" | "2" | "3" | "4" |
| PH4E48 | 81 | 37 | 56 | 25 |

REQUIRED CLEARANCES TO COMBUSTIBLE MATL.

INCHES [MM]

TOP OF UNIT.....14 [355.61]
 DUCT SIDE OF UNIT.....2 [50.81]
 SIDE OPPOSITE DUCTS.....14 [355.61]
 BOTTOM OF UNIT.....14 [355.61]
 ELECTRICAL PANEL.....36 [914.41]

NEC. REQUIRED CLEARANCES.

INCHES [MM]

BETWEEN UNITS, POWER ENTRY SIDE.....42 [1066.81]
 UNIT AND BUNGLED COILS, POWER ENTRY SIDE.....36 [914.01]
 UNIT AND BUNGLED COILS, POWER AND OTHER GROUNDING SURFACES, POWER ENTRY SIDE.....42 [1066.81]

REQUIRED CLEARANCE FOR OPERATION AND SERVICING

INCHES [MM]

EVAP. COIL ACCESS SIDE.....36 [914.01]
 POWER ENTRY SIDE.....42 [1066.81]
 LOWER PANEL FOR NEC REQUIREMENTS.....48 [1219.21]
 UNIT TOP OPPOSITE DUCTS.....36 [914.01]
 SIDE OPPOSITE DUCTS.....36 [914.01]
 DUCT PANEL.....12 [304.81]

*MINIMUM DISTANCES: IF UNIT IS PLACED LESS THAN 12 [304.81] FROM WALL SYSTEM, THEN SYSTEM PERFORMANCE MAY BE COMPROMISED.

DIMENSIONS IN 1/8 ARE IN MILLIMETERS

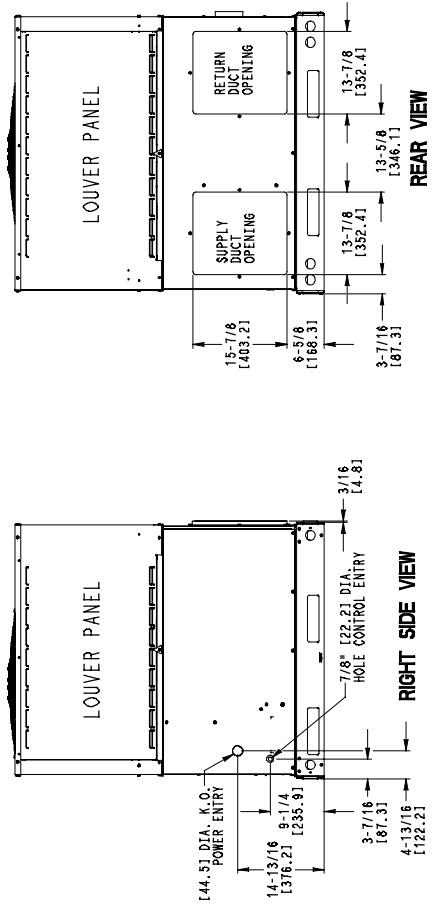
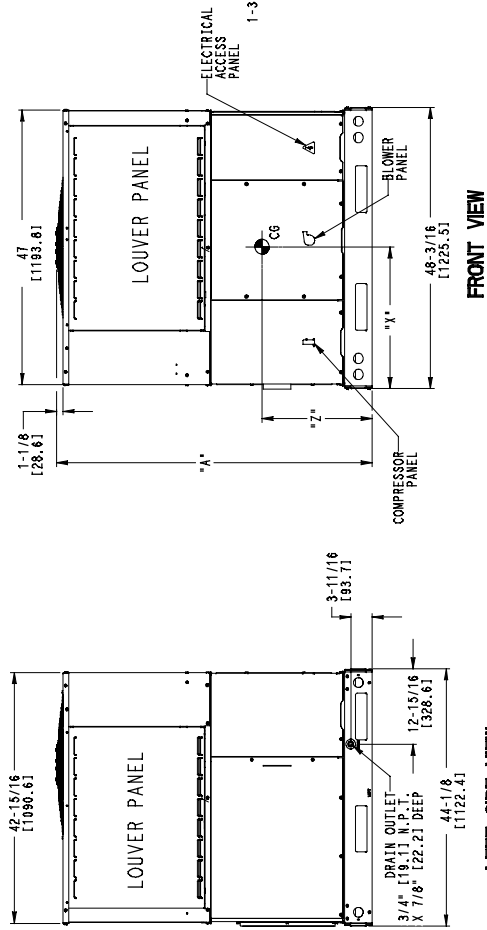
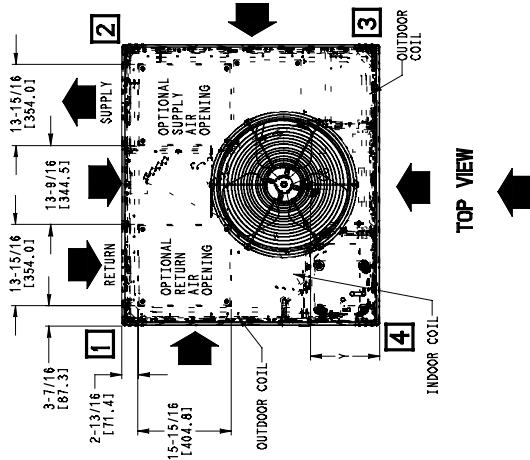

ACCESSORY ROOF CURB - PH4E24-48

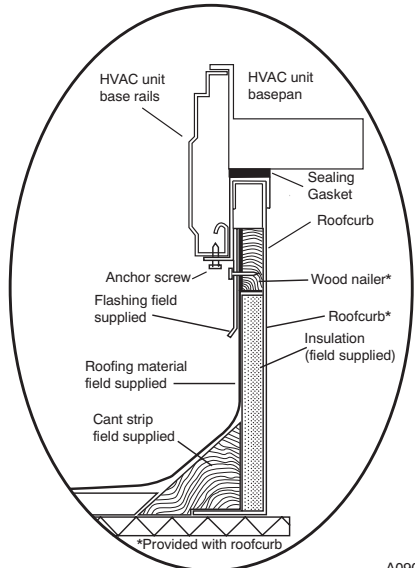

A09090

ROOF CURB DETAIL

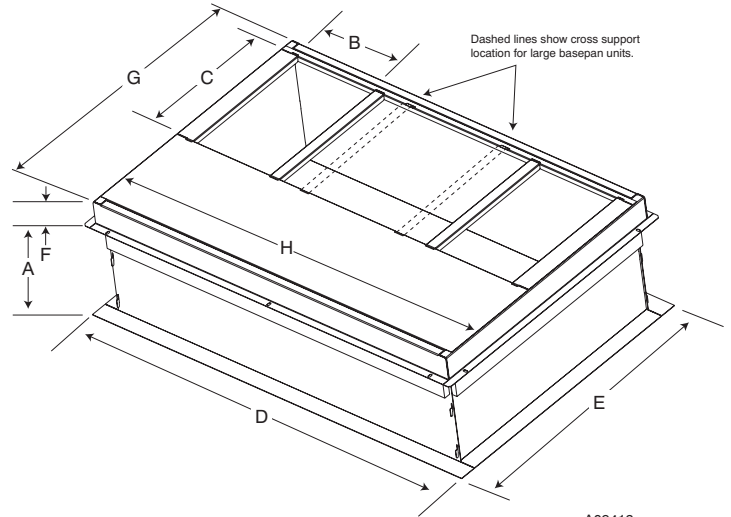

SMALL/COMMON CURB

A09413

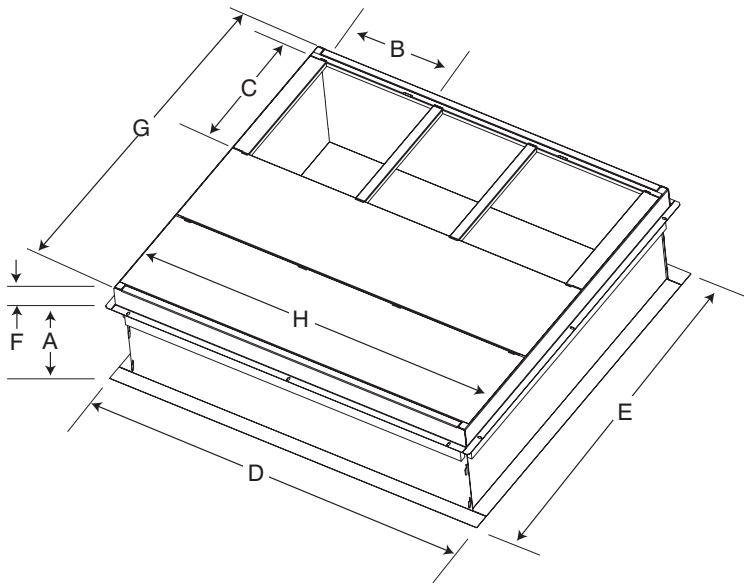

LARGE CURB

A09415

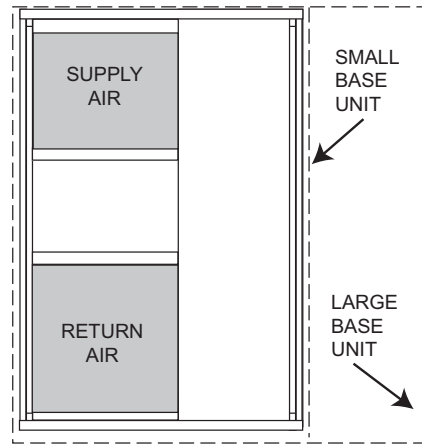

UNIT PLACEMENT ON COMMON CURB

A09094

SMALL OR LARGE BASE UNIT

A09414

| UNIT SIZE | CATALOG NUMBER | A IN. (mm) | B (small/common curb) IN. (mm)* | B (large curb) IN. (mm)* | C IN. (mm) | D IN. (mm) | E IN. (mm) | F IN. (mm) | G IN. (mm) | H IN. (mm) |
|----------------|----------------|------------|---------------------------------|--------------------------|------------|-------------|-------------|------------|------------|-------------|
| Small or Large | CPRFCURB010A00 | 11 (279) | 10 (254) | 14 (356) | 16 (406) | 47.8 (1214) | 32.4 (822) | 2.7 (69) | 30.6 (778) | 46.1 (1170) |
| | CPRFCURB011A00 | 14 (356) | 14 (356) | | | | 43.9 (1116) | | | |
| Large | CPRFCURB012A00 | 11 (279) | 14 (356) | 14 (356) | 16 (406) | 47.8 (1214) | 32.4 (822) | 2.7 (69) | 30.6 (778) | 46.1 (1170) |
| | CPRFCURB013A00 | 14 (356) | 14 (356) | | | | 43.9 (1116) | | | |

* Part Numbers CPRFCURB010A00 and CPRFCURB011A00 can be used on both small and large basepan units. The cross supports must be located based on whether the unit is a small basepan or a large basepan.

NOTES:

1. Roof curb must be set up for unit being installed.
2. Seal strip must be applied, as required, to unit being installed.
3. Roof curb is made of 16-gauge steel.
4. Attach ductwork to curb (flanges of duct rest on curb).
5. Insulated panels: 1-in. (25.4 mm) thick fiberglass 1 lb. density.

SELECTION PROCEDURE (WITH EXAMPLE)

1. Determine cooling and heating requirements at design conditions:

Given:

Required Cooling Capacity (TC) . . . 10.4kW (35,000 Btuh)
Sensible Heat Capacity (SHC) 7.3 kW (25,000 Btuh)
Required Heating Capacity 6.4 kW (22,000 Btuh)
Condenser Entering Air Temperature 35°C (95°F)
Indoor-Air Temperature 26.7°C (80°F) edb
. 19°C (67°F) ewb
Evaporator Air Quantity 543 L/s (1150 CFM)
External Static Pressure 24.9 Pa (0.1 IN. W.C.)
Electrical Characteristics 400-3-50

2. Select unit based on required cooling capacity.

A. SI

Enter Net Cooling Capacities SI table at condenser entering temperature of 35°C, which matches design Condenser Entering Air Temperature. At 566 L/s and 19°C ewb (entering wet bulb) will provide a total capacity of 12.5 kW and a SHC of 9.1 kW. Calculate SHC correction, if required using Note 3 of Net Cooling Capacities Table.

3. Select electric heat.

The required heating capacity is 6.4 kW (22,000 Btuh)-(given).

Determine additional electric heat capacity in kW.

$$\frac{22,000 \text{ Btuh}}{3,414 \text{ Btuh/kW}} = 6.44 \text{ kW of heat required}$$

Enter the Electric Heater table for the unit. The 6.5 kW heater at 400v most closely satisfies the heating required.

4. Determine fan speed and power requirements at design conditions.

Before entering the air delivery tables, calculate the total static pressure required. From the given Filter Pressure Drop Table find:

| | |
|--------------------------|---------------------------------|
| External Static Pressure | 12.5 Pa (0.05 IN. W.C.) |
| Filter | <u>+20/0 Pa (0.12 IN. W.C.)</u> |
| Total Static Pressure | 42.4 Pa (0.17 IN. W.C.) |

Enter the table for Wet Coil Air Delivery—Horizontal Discharge, 400 V. At 0.424 Pa (0.17 IN. W.C.) external static pressure and low speed, the fan will deliver 561 L/s (1188 CFM).

PERFORMANCE DATA

PH4E24 Cooling Extended Performance Table English

| Temp (°F) Outdoor Air Entering Condenser | Evaporator Air—CFM/BF | | | | | | | | | | | |
|--|-----------------------|------|------|------|-----------|------|------|------|-----------|------|------|------|
| | 700/0.055 | | | | 800/0.063 | | | | 900/0.082 | | | |
| | 62 | 67 | 72 | 72 | 62 | 67 | 72 | 72 | 62 | 67 | 72 | 72 |
| 75 | TC | 23.7 | 29.1 | 28.9 | 24.1 | 27.1 | 29.1 | 29.1 | 24.4 | 27.3 | 29.1 | 29.1 |
| | SHC | 20.3 | 14.0 | 13.6 | 21.5 | 18.1 | 13.9 | 13.9 | 22.6 | 18.8 | 14.0 | 14.0 |
| | KW | 1.8 | 2.1 | 1.9 | 1.9 | 2.0 | 2.1 | 2.1 | 2.0 | 2.1 | 2.1 | 2.1 |
| 85 | TC | 22.4 | 25.0 | 27.8 | 22.7 | 25.6 | 28.1 | 28.1 | 23.3 | 25.8 | 28.3 | 28.3 |
| | SHC | 19.6 | 16.5 | 13.4 | 20.8 | 17.6 | 13.8 | 13.8 | 21.6 | 18.4 | 14.0 | 14.0 |
| | KW | 2.0 | 2.1 | 2.1 | 2.1 | 2.2 | 2.2 | 2.2 | 2.2 | 2.3 | 2.3 | 2.3 |
| 95 | TC | 20.9 | 23.5 | 26.5 | 21.5 | 23.9 | 26.8 | 26.8 | 22.2 | 24.2 | 26.9 | 26.9 |
| | SHC | 18.9 | 16.0 | 12.9 | 19.9 | 17.0 | 13.4 | 13.4 | 20.5 | 17.9 | 13.7 | 13.7 |
| | KW | 2.3 | 2.3 | 2.3 | 2.3 | 2.4 | 2.4 | 2.4 | 2.4 | 2.5 | 2.5 | 2.5 |
| 105 | TC | 19.5 | 21.8 | 24.8 | 20.4 | 22.2 | 25.1 | 25.1 | 20.9 | 22.4 | 25.2 | 25.2 |
| | SHC | 18.1 | 15.4 | 12.3 | 18.8 | 16.4 | 12.9 | 12.9 | 19.4 | 17.3 | 13.2 | 13.2 |
| | KW | 2.5 | 2.6 | 2.6 | 2.6 | 2.7 | 2.7 | 2.7 | 2.7 | 2.8 | 2.8 | 2.8 |
| 115 | TC | 18.3 | 20.1 | 22.9 | 19.0 | 20.4 | 23.2 | 23.2 | 19.6 | 20.5 | 23.3 | 23.3 |
| | SHC | 16.9 | 14.7 | 11.7 | 17.6 | 15.7 | 12.2 | 12.2 | 18.1 | 16.6 | 12.6 | 12.6 |
| | KW | 2.8 | 2.8 | 2.9 | 2.9 | 2.9 | 3.0 | 3.0 | 2.9 | 3.0 | 3.1 | 3.1 |
| 125 | TC | 16.8 | 18.1 | 20.9 | 17.5 | 18.3 | 21.1 | 21.1 | 18.1 | 18.4 | 21.2 | 21.2 |
| | SHC | 15.6 | 14.0 | 11.0 | 16.2 | 15.0 | 11.5 | 11.5 | 16.7 | 15.8 | 11.9 | 11.9 |
| | KW | 3.1 | 3.1 | 3.2 | 3.2 | 3.2 | 3.2 | 3.3 | 3.2 | 3.3 | 3.4 | 3.4 |

See Legend and Notes following.

PH4E24 Cooling Extended Performance Table SI

| Temp (°C) Outdoor Air Entering Condenser | Evaporator Air—L/s—BF | | | | | | | | | | | |
|--|-----------------------|-----|-----|-----|-----------|-----|-----|-----|----------|-----|-----|-----|
| | 330/0.055 | | | | 377/0.063 | | | | 425/0.82 | | | |
| | 17 | 19 | 22 | 22 | 17 | 19 | 22 | 22 | 17 | 19 | 22 | 22 |
| 24 | TC | 6.8 | 7.6 | 8.2 | 6.9 | 7.7 | 8.2 | 8.2 | 7.1 | 7.7 | 8.2 | 8.2 |
| | SHC | 6.0 | 5.0 | 4.0 | 6.4 | 5.3 | 4.0 | 4.0 | 6.8 | 5.4 | 4.1 | 4.1 |
| | KW | 1.9 | 1.9 | 1.9 | 1.9 | 2.0 | 2.0 | 2.0 | 2.0 | 2.1 | 2.1 | 2.1 |
| 29 | TC | 6.4 | 7.2 | 7.9 | 6.5 | 7.3 | 7.9 | 7.9 | 6.8 | 7.4 | 7.9 | 7.9 |
| | SHC | 5.8 | 4.9 | 3.9 | 6.2 | 5.1 | 4.0 | 4.0 | 6.5 | 5.4 | 4.0 | 4.0 |
| | KW | 2.0 | 2.1 | 2.1 | 2.1 | 2.2 | 2.2 | 2.2 | 2.2 | 2.3 | 2.3 | 2.3 |
| 35 | TC | 6.0 | 6.8 | 7.5 | 6.2 | 6.9 | 7.6 | 7.6 | 6.4 | 6.9 | 7.6 | 7.6 |
| | SHC | 5.6 | 4.7 | 3.8 | 5.9 | 5.0 | 3.9 | 3.9 | 6.1 | 5.2 | 3.9 | 3.9 |
| | KW | 2.2 | 2.3 | 2.3 | 2.3 | 2.4 | 2.4 | 2.4 | 2.4 | 2.5 | 2.5 | 2.5 |
| 41 | TC | 5.6 | 6.3 | 7.1 | 5.9 | 6.4 | 7.2 | 7.2 | 6.1 | 6.5 | 7.2 | 7.2 |
| | SHC | 5.4 | 4.5 | 3.6 | 5.6 | 4.8 | 3.7 | 3.7 | 5.8 | 5.1 | 3.8 | 3.8 |
| | KW | 2.4 | 2.6 | 2.6 | 2.5 | 2.7 | 2.7 | 2.7 | 2.6 | 2.7 | 2.8 | 2.8 |
| 46 | TC | 5.3 | 5.8 | 6.6 | 5.5 | 5.9 | 6.7 | 6.7 | 5.7 | 6.0 | 6.7 | 6.7 |
| | SHC | 5.1 | 4.3 | 3.4 | 5.3 | 4.6 | 3.6 | 3.6 | 5.4 | 4.9 | 3.6 | 3.6 |
| | KW | 2.7 | 2.8 | 2.8 | 2.8 | 2.9 | 2.9 | 2.9 | 2.9 | 3.0 | 3.0 | 3.0 |
| 52 | TC | 4.9 | 5.4 | 6.1 | 5.1 | 5.4 | 6.1 | 6.1 | 5.3 | 5.5 | 6.1 | 6.1 |
| | SHC | 4.7 | 4.1 | 3.2 | 4.9 | 4.4 | 3.4 | 3.4 | 5.1 | 4.7 | 3.5 | 3.5 |
| | KW | 2.9 | 3.0 | 3.1 | 3.0 | 3.2 | 3.2 | 3.2 | 3.2 | 3.3 | 3.3 | 3.3 |

See Legend and Notes following.

PERFORMANCE DATA PH4E24 Heating Extended Performance Table English

| Return Air (°F db) | CFM | | Air Temperature Entering Outdoor Coil (F) | | | | | | | | | | | | | | | | | | | | |
|--------------------|----------------|----|---|-------|-------|-------|-------|-------|-------|-------|-------|-------|-------|-------|-------|-------|-------|-------|-------|-------|-------|-------|-------|
| | (Standard Air) | | -10 | 0 | 10 | 17 | 20 | 30 | 40 | 47 | 50 | 60 | | | | | | | | | | | |
| 60 | 700 | IC | 13.85 | 12.81 | 15.20 | 13.99 | 16.55 | 16.19 | 27.90 | 25.44 | 18.19 | 16.50 | 20.59 | 18.04 | 23.14 | 23.14 | 25.17 | 25.65 | 25.65 | 26.91 | 26.91 | | |
| | | KW | 1.70 | 1.70 | 1.78 | 1.86 | 1.86 | 1.92 | 1.94 | 2.04 | 2.12 | 2.21 | 2.23 | 2.23 | 2.23 | 2.23 | 2.23 | 2.23 | 2.23 | 2.23 | 2.29 | 2.29 | |
| | 800 | IC | 16.22 | 16.00 | 17.10 | 15.74 | 17.99 | 16.51 | 18.61 | 16.97 | 19.18 | 17.39 | 21.14 | 18.52 | 23.19 | 23.19 | 24.68 | 24.68 | 25.01 | 25.01 | 26.02 | 26.02 | |
| | | KW | 1.83 | 1.83 | 1.88 | 1.92 | 1.92 | 1.96 | 1.97 | 2.03 | 2.14 | 2.15 | 2.15 | 2.15 | 2.15 | 2.15 | 2.14 | 2.14 | 2.15 | 2.15 | 2.19 | 2.19 | |
| | 900 | IC | 17.70 | 18.37 | 18.25 | 16.79 | 18.80 | 17.25 | 19.18 | 17.49 | 19.66 | 17.83 | 21.28 | 18.64 | 22.96 | 22.96 | 24.15 | 24.15 | 24.38 | 24.38 | 24.99 | 24.99 | |
| | | KW | 1.88 | 1.88 | 1.91 | 1.94 | 1.94 | 1.96 | 1.98 | 2.02 | 2.10 | 2.11 | 2.11 | 2.11 | 2.08 | 2.08 | 2.10 | 2.10 | 2.11 | 2.11 | 2.14 | 2.14 | |
| 70 | 700 | IC | 9.52 | 8.80 | 11.46 | 10.56 | 13.41 | 12.31 | 14.78 | 13.47 | 15.61 | 14.16 | 18.52 | 16.23 | 21.64 | 21.64 | 23.92 | 23.92 | 24.65 | 24.65 | 26.88 | 26.88 | |
| | | KW | 1.80 | 1.80 | 1.89 | 1.97 | 1.97 | 2.03 | 2.06 | 2.16 | 2.32 | 2.35 | 2.35 | 2.26 | 2.26 | 2.32 | 2.32 | 2.35 | 2.35 | 2.44 | 2.44 | | |
| | 800 | IC | 7.16 | 6.62 | 9.72 | 8.95 | 12.29 | 11.28 | 14.09 | 12.84 | 15.10 | 13.69 | 18.64 | 22.35 | 22.35 | 25.42 | 25.42 | 25.42 | 25.42 | 26.26 | 26.26 | 29.09 | 29.09 |
| | | KW | 1.72 | 1.72 | 1.82 | 1.93 | 1.93 | 2.00 | 2.04 | 2.16 | 2.27 | 2.27 | 2.27 | 2.27 | 2.27 | 2.27 | 2.27 | 2.27 | 2.27 | 2.40 | 2.40 | 2.50 | 2.50 |
| | 900 | IC | 9.13 | 8.44 | 11.30 | 10.40 | 13.48 | 12.37 | 15.00 | 13.68 | 15.91 | 14.43 | 19.07 | 16.71 | 22.63 | 22.63 | 25.02 | 25.02 | 25.41 | 25.41 | 28.44 | 28.44 | |
| | | KW | 1.81 | 1.81 | 1.89 | 1.98 | 1.98 | 2.04 | 2.07 | 2.17 | 2.34 | 2.36 | 2.36 | 2.27 | 2.27 | 2.34 | 2.34 | 2.36 | 2.36 | 2.45 | 2.45 | | |
| 80 | 700 | IC | 7.53 | 8.96 | 9.12 | 8.39 | 10.72 | 9.84 | 11.83 | 10.79 | 12.51 | 11.39 | 14.88 | 13.30 | 17.35 | 17.35 | 19.35 | 19.35 | 19.89 | 19.89 | 21.65 | 21.65 | |
| | | KW | 1.77 | 1.77 | 1.85 | 1.85 | 1.93 | 1.99 | 2.02 | 2.12 | 2.28 | 2.31 | 2.31 | 2.21 | 2.21 | 2.28 | 2.28 | 2.31 | 2.31 | 2.40 | 2.40 | | |
| | 800 | IC | 9.00 | 8.32 | 10.66 | 9.81 | 12.33 | 11.31 | 13.49 | 12.30 | 14.22 | 12.89 | 16.75 | 14.68 | 19.52 | 19.52 | 21.39 | 21.39 | 22.01 | 22.01 | 24.02 | 24.02 | |
| | | KW | 1.69 | 1.69 | 1.80 | 1.80 | 1.90 | 1.98 | 2.01 | 2.13 | 2.27 | 2.27 | 2.27 | 2.27 | 2.27 | 2.27 | 2.27 | 2.27 | 2.37 | 2.37 | 2.49 | 2.49 | |
| | 900 | IC | 8.25 | 7.63 | 10.30 | 9.48 | 12.35 | 11.33 | 13.79 | 12.57 | 14.63 | 13.27 | 17.60 | 15.42 | 20.90 | 20.90 | 23.07 | 23.07 | 23.73 | 23.73 | 26.33 | 26.33 | |
| | | KW | 1.84 | 1.84 | 1.93 | 1.93 | 2.03 | 2.09 | 2.13 | 2.23 | 2.42 | 2.45 | 2.45 | 2.34 | 2.34 | 2.42 | 2.42 | 2.45 | 2.45 | 2.54 | 2.54 | | |

See Legend and Notes following.

PH4E24 Heating Extended Performance Table SI

| Return Air (°C db) | L/s | | Air Temperature Entering Outdoor Coil (C) | | | | | | | | | | | | | | | | | | | |
|--------------------|----------------|----------|---|------|------|------|------|------|------|------|------|------|------|------|------|------|------|------|------|------|------|------|
| | (Standard Air) | | -23 | -18 | -12 | -8 | -7 | -1 | 4 | 8 | 10 | 16 | | | | | | | | | | |
| 16 | 330 | Cap (kW) | 4.06 | 3.75 | 4.45 | 4.10 | 4.85 | 4.45 | 8.17 | 7.46 | 5.33 | 4.63 | 6.03 | 5.28 | 6.78 | 6.76 | 7.37 | 7.37 | 7.51 | 7.51 | 7.88 | 7.88 |
| | | KW | 1.70 | 1.70 | 1.78 | 1.78 | 1.86 | 1.92 | 1.94 | 2.04 | 2.12 | 2.21 | 2.23 | 2.23 | 2.23 | 2.23 | 2.23 | 2.23 | 2.23 | 2.23 | 2.29 | 2.29 |
| | 377 | Cap (kW) | 4.75 | 4.39 | 5.01 | 4.61 | 5.27 | 4.63 | 5.45 | 4.97 | 5.62 | 5.09 | 6.19 | 5.42 | 6.79 | 6.79 | 7.23 | 7.23 | 7.32 | 7.32 | 7.62 | 7.62 |
| | | KW | 1.83 | 1.83 | 1.88 | 1.88 | 1.92 | 1.96 | 1.97 | 2.03 | 2.09 | 2.14 | 2.15 | 2.15 | 2.09 | 2.09 | 2.14 | 2.14 | 2.15 | 2.15 | 2.19 | 2.19 |
| | 425 | Cap (kW) | 1.58 | 4.79 | 5.34 | 4.92 | 5.50 | 5.05 | 5.62 | 5.12 | 5.76 | 5.22 | 6.23 | 5.46 | 6.72 | 6.72 | 7.07 | 7.07 | 7.14 | 7.14 | 7.32 | 7.32 |
| | | KW | 1.88 | 1.88 | 1.91 | 1.91 | 1.94 | 1.94 | 1.96 | 1.96 | 1.98 | 2.02 | 2.02 | 2.02 | 2.07 | 2.07 | 2.10 | 2.10 | 2.11 | 2.11 | 2.14 | 2.14 |
| 21 | 330 | Cap (kW) | 2.79 | 2.58 | 3.36 | 3.09 | 3.93 | 3.60 | 4.33 | 3.95 | 4.57 | 4.15 | 5.42 | 4.75 | 6.34 | 6.34 | 7.00 | 7.00 | 7.22 | 7.22 | 7.87 | 7.87 |
| | | KW | 1.80 | 1.80 | 1.89 | 1.89 | 1.97 | 1.97 | 2.03 | 2.06 | 2.16 | 2.26 | 2.26 | 2.16 | 2.16 | 2.26 | 2.26 | 2.32 | 2.32 | 2.35 | 2.35 | 2.44 |
| | 377 | Cap (kW) | 2.10 | 1.94 | 2.85 | 2.62 | 3.60 | 3.30 | 4.12 | 3.76 | 4.42 | 4.01 | 5.46 | 4.76 | 6.54 | 6.54 | 7.44 | 7.44 | 7.69 | 7.69 | 8.52 | 8.52 |
| | | KW | 1.72 | 1.72 | 1.82 | 1.82 | 1.93 | 1.93 | 2.00 | 2.04 | 2.04 | 2.04 | 2.04 | 2.04 | 2.27 | 2.27 | 2.38 | 2.38 | 2.40 | 2.40 | 2.50 | 2.50 |
| | 425 | Cap (kW) | 2.67 | 2.47 | 3.31 | 3.05 | 3.95 | 3.62 | 4.39 | 4.01 | 4.66 | 4.22 | 5.59 | 4.89 | 6.62 | 6.62 | 7.33 | 7.33 | 7.44 | 7.44 | 8.33 | 8.33 |
| | | KW | 1.81 | 1.81 | 1.89 | 1.89 | 1.98 | 1.98 | 2.04 | 2.07 | 2.07 | 2.07 | 2.17 | 2.17 | 2.27 | 2.27 | 2.34 | 2.34 | 2.36 | 2.36 | 2.45 | 2.45 |
| 27 | 330 | Cap (kW) | 2.20 | 2.04 | 2.67 | 2.46 | 3.14 | 2.68 | 3.46 | 3.16 | 3.66 | 3.32 | 4.36 | 3.82 | 5.08 | 5.08 | 5.67 | 5.67 | 5.82 | 5.82 | 6.34 | 6.34 |
| | | KW | 1.77 | 1.77 | 1.85 | 1.85 | 1.93 | 1.93 | 1.99 | 2.02 | 2.02 | 2.02 | 2.12 | 2.12 | 2.21 | 2.21 | 2.29 | 2.29 | 2.31 | 2.31 | 2.40 | 2.40 |
| | 377 | Cap (kW) | 2.63 | 2.44 | 3.12 | 2.37 | 3.61 | 3.31 | 3.95 | 3.60 | 4.16 | 3.76 | 4.90 | 4.30 | 5.72 | 5.72 | 6.26 | 6.26 | 6.44 | 6.44 | 7.03 | 7.03 |
| | | KW | 1.69 | 1.69 | 1.80 | 1.80 | 1.90 | 1.90 | 1.98 | 2.01 | 2.01 | 2.01 | 2.13 | 2.13 | 2.27 | 2.27 | 2.33 | 2.33 | 2.37 | 2.37 | 2.49 | 2.49 |
| | 425 | Cap (kW) | 2.41 | 2.23 | 3.02 | 2.77 | 3.62 | 3.32 | 4.04 | 3.65 | 4.28 | 3.89 | 5.15 | 4.51 | 6.12 | 6.12 | 6.76 | 6.76 | 6.95 | 6.95 | 7.71 | 7.71 |
| | | KW | 1.84 | 1.84 | 1.93 | 1.93 | 2.03 | 2.03 | 2.09 | 2.13 | 2.13 | 2.13 | 2.23 | 2.23 | 2.34 | 2.34 | 2.42 | 2.42 | 2.45 | 2.45 | 2.54 | 2.54 |

See Legend and Notes following.

PERFORMANCE DATA (CONT)

PH4E30 Cooling Extended Performance Table English

| Temp (°F) Outdoor Air Entering Condenser | Evaporator Air—CFM/BF | | | | | | | | | | | | | | | | |
|--|-----------------------|------|------|------|------|------|-----------|------|------|------|------|------|-----------|------|------|------|------|
| | 875/0.089 | | | | | | 1000/0.11 | | | | | | 1125/0.14 | | | | |
| | 62 | 67 | 72 | 62 | 67 | 72 | 62 | 67 | 72 | 62 | 67 | 72 | 62 | 67 | 72 | | |
| 75 | TC | 28.4 | 31.6 | 33.9 | 29.1 | 32.2 | 34.4 | 34.4 | 30.2 | 32.7 | 34.7 | 30.2 | 32.7 | 34.7 | 30.2 | 32.7 | 34.7 |
| | SHC | 21.2 | 23.6 | 25.3 | 21.7 | 24.0 | 25.7 | 25.7 | 22.5 | 24.4 | 25.9 | 22.5 | 24.4 | 25.9 | 22.5 | 24.4 | 25.9 |
| | KW | 2.3 | 2.4 | 2.4 | 2.4 | 2.4 | 2.4 | 2.4 | 2.4 | 2.4 | 2.4 | 2.4 | 2.4 | 2.4 | 2.4 | 2.4 | 2.4 |
| 85 | TC | 26.9 | 30.2 | 32.7 | 27.6 | 30.8 | 33.2 | 33.2 | 28.6 | 31.3 | 33.6 | 28.6 | 31.3 | 33.6 | 28.6 | 31.3 | 33.6 |
| | SHC | 20.1 | 22.6 | 24.4 | 20.6 | 23.0 | 24.8 | 24.8 | 21.4 | 23.4 | 25.0 | 21.4 | 23.4 | 25.0 | 21.4 | 23.4 | 25.0 |
| | KW | 2.6 | 2.7 | 2.7 | 2.6 | 2.7 | 2.7 | 2.7 | 2.7 | 2.7 | 2.7 | 2.7 | 2.7 | 2.7 | 2.7 | 2.7 | 2.7 |
| 95 | TC | 25.5 | 28.5 | 31.3 | 26.6 | 29.4 | 31.8 | 31.8 | 27.2 | 29.8 | 32.1 | 27.2 | 29.8 | 32.1 | 27.2 | 29.8 | 32.1 |
| | SHC | 19.0 | 21.3 | 23.4 | 19.9 | 21.9 | 23.7 | 23.7 | 20.3 | 22.2 | 24.0 | 20.3 | 22.2 | 24.0 | 20.3 | 22.2 | 24.0 |
| | KW | 2.9 | 3.0 | 3.0 | 2.9 | 3.0 | 3.0 | 3.0 | 3.0 | 3.0 | 3.0 | 3.0 | 3.0 | 3.0 | 3.0 | 3.0 | 3.0 |
| 105 | TC | 24.0 | 26.7 | 29.7 | 24.9 | 27.4 | 30.4 | 30.4 | 25.8 | 27.9 | 30.7 | 25.8 | 27.9 | 30.7 | 25.8 | 27.9 | 30.7 |
| | SHC | 17.9 | 20.0 | 22.2 | 18.6 | 20.5 | 22.7 | 22.7 | 19.3 | 20.8 | 22.9 | 19.3 | 20.8 | 22.9 | 19.3 | 20.8 | 22.9 |
| | KW | 3.2 | 3.3 | 3.3 | 3.2 | 3.3 | 3.3 | 3.3 | 3.3 | 3.3 | 3.4 | 3.3 | 3.3 | 3.4 | 3.3 | 3.3 | 3.4 |
| 115 | TC | 22.7 | 25.0 | 28.1 | 23.6 | 25.6 | 28.5 | 28.5 | 24.4 | 25.9 | 28.8 | 24.4 | 25.9 | 28.8 | 24.4 | 25.9 | 28.8 |
| | SHC | 16.9 | 18.7 | 21.0 | 17.6 | 19.1 | 21.2 | 21.2 | 18.2 | 19.3 | 21.5 | 18.2 | 19.3 | 21.5 | 18.2 | 19.3 | 21.5 |
| | KW | 3.6 | 3.6 | 3.7 | 3.6 | 3.7 | 3.7 | 3.7 | 3.7 | 3.7 | 3.7 | 3.7 | 3.7 | 3.7 | 3.7 | 3.7 | 3.7 |
| 125 | TC | 21.3 | 23.2 | 25.9 | 22.2 | 23.6 | 26.3 | 26.3 | 23.0 | 24.0 | 26.6 | 23.0 | 24.0 | 26.6 | 23.0 | 24.0 | 26.6 |
| | SHC | 15.9 | 17.3 | 19.4 | 16.6 | 17.6 | 19.6 | 19.6 | 17.1 | 17.9 | 19.8 | 17.1 | 17.9 | 19.8 | 17.1 | 17.9 | 19.8 |
| | KW | 4.0 | 4.0 | 4.0 | 4.0 | 4.1 | 4.1 | 4.1 | 4.1 | 4.1 | 4.1 | 4.1 | 4.1 | 4.1 | 4.1 | 4.1 | 4.1 |

See Legend and Notes following.

PH4E30 Cooling Extended Performance Table SI

| Temp (°C) Outdoor Air Entering Condenser | Evaporator Air—L/s—BF | | | | | | | | | | | | | | | | |
|--|-----------------------|-----|-----|------|-----|-----|-----------|------|-----|-----|------|-----|-----------|------|-----|-----|------|
| | 413/0.089 | | | | | | 472/0.011 | | | | | | 531/0.014 | | | | |
| | 17 | 19 | 22 | 17 | 19 | 22 | 17 | 19 | 22 | 17 | 19 | 22 | 17 | 19 | 22 | | |
| 24 | TC | 8.5 | 9.3 | 10.2 | 8.6 | 9.4 | 10.3 | 10.3 | 8.8 | 9.4 | 10.4 | 8.8 | 9.4 | 10.4 | 8.8 | 9.4 | 10.4 |
| | SHC | 7.5 | 6.2 | 5.0 | 8.0 | 6.6 | 5.2 | 5.2 | 6.6 | 6.9 | 5.3 | 6.6 | 6.9 | 5.3 | 6.6 | 6.9 | 5.3 |
| | KW | 2.4 | 2.5 | 2.5 | 2.5 | 2.6 | 2.6 | 2.6 | 2.6 | 2.6 | 2.8 | 2.6 | 2.7 | 2.8 | 2.6 | 2.7 | 2.8 |
| 29 | TC | 8.1 | 8.9 | 9.8 | 8.2 | 9.0 | 9.9 | 9.9 | 8.5 | 9.0 | 9.9 | 8.5 | 9.0 | 9.9 | 8.5 | 9.0 | 9.9 |
| | SHC | 7.3 | 6.1 | 4.8 | 7.8 | 6.4 | 5.0 | 5.0 | 8.1 | 6.7 | 5.2 | 8.1 | 6.7 | 5.2 | 8.1 | 6.7 | 5.2 |
| | KW | 2.7 | 2.7 | 2.8 | 2.8 | 2.8 | 2.9 | 2.9 | 2.8 | 2.8 | 3.0 | 2.8 | 2.8 | 3.0 | 2.8 | 2.8 | 3.0 |
| 35 | TC | 7.7 | 8.5 | 9.3 | 7.9 | 8.5 | 9.4 | 9.4 | 8.1 | 8.6 | 9.4 | 8.1 | 8.6 | 9.4 | 8.1 | 8.6 | 9.4 |
| | SHC | 7.1 | 5.9 | 4.7 | 7.6 | 6.2 | 4.9 | 4.9 | 7.8 | 6.6 | 5.0 | 7.8 | 6.6 | 5.0 | 7.8 | 6.6 | 5.0 |
| | KW | 3.0 | 3.0 | 3.0 | 3.0 | 3.1 | 3.2 | 3.2 | 3.1 | 3.2 | 3.3 | 3.1 | 3.2 | 3.3 | 3.1 | 3.2 | 3.3 |
| 41 | TC | 7.4 | 8.0 | 8.9 | 7.6 | 8.1 | 8.9 | 8.9 | 7.8 | 8.1 | 8.9 | 7.8 | 8.1 | 8.9 | 7.8 | 8.1 | 8.9 |
| | SHC | 6.9 | 5.7 | 4.5 | 7.2 | 6.1 | 4.7 | 4.7 | 7.4 | 6.4 | 4.8 | 7.4 | 6.4 | 4.8 | 7.4 | 6.4 | 4.8 |
| | KW | 3.3 | 3.3 | 3.4 | 3.3 | 3.4 | 3.5 | 3.5 | 3.4 | 3.6 | 3.6 | 3.4 | 3.6 | 3.6 | 3.4 | 3.6 | 3.6 |
| 46 | TC | 7.0 | 7.6 | 8.4 | 7.2 | 7.7 | 8.4 | 8.4 | 7.4 | 7.7 | 8.4 | 7.4 | 7.7 | 8.4 | 7.4 | 7.7 | 8.4 |
| | SHC | 6.7 | 5.6 | 4.3 | 6.9 | 5.9 | 4.5 | 4.5 | 7.1 | 6.2 | 4.7 | 7.1 | 6.2 | 4.7 | 7.1 | 6.2 | 4.7 |
| | KW | 3.6 | 3.7 | 3.7 | 3.7 | 3.8 | 3.8 | 3.8 | 3.8 | 3.8 | 4.0 | 3.8 | 3.8 | 4.0 | 3.8 | 3.8 | 4.0 |
| 52 | TC | 6.7 | 7.2 | 8.0 | 6.9 | 7.2 | 8.0 | 8.0 | 7.0 | 7.3 | 8.0 | 7.0 | 7.3 | 8.0 | 7.0 | 7.3 | 8.0 |
| | SHC | 6.4 | 5.4 | 4.2 | 6.6 | 5.8 | 4.4 | 4.4 | 6.7 | 6.1 | 4.5 | 6.7 | 6.1 | 4.5 | 6.7 | 6.1 | 4.5 |
| | KW | 4.0 | 4.1 | 4.1 | 4.1 | 4.2 | 4.2 | 4.2 | 4.2 | 4.3 | 4.4 | 4.2 | 4.3 | 4.4 | 4.2 | 4.3 | 4.4 |

See Legend and Notes following.

PERFORMANCE DATA

PH4E30 Heating Extended Performance Table English

| Return Air (° F db) | CFM | Air Temperature Entering Outdoor Coil (F) | | | | | | | | | | | | | | | | | | | |
|---------------------|-------------------|---|------|-------|-------|-------|-------|-------|-------|-------|-------|-------|-------|-------|-------|-------|-------|-------|-------|-------|-------|
| | | -10 | 0 | 10 | 17 | 20 | 30 | 40 | 47 | 50 | 60 | | | | | | | | | | |
| 60 | IC (Standard Air) | 7.32 | 6.77 | 10.70 | 9.86 | 14.08 | 12.93 | 27.90 | 25.44 | 17.70 | 15.05 | 21.42 | 18.77 | 25.74 | 25.74 | 29.30 | 29.30 | 30.55 | 30.55 | 34.07 | 34.07 |
| | KW | 1.77 | 1.94 | 2.10 | 2.22 | 2.24 | 2.34 | 2.44 | 2.52 | 2.56 | 2.68 | 2.85 | 2.98 | 3.01 | 3.09 | 3.12 | 3.21 | 3.27 | 3.31 | 3.47 | 3.47 |
| | Cap (KW) | 7.63 | 7.06 | 11.03 | 10.15 | 14.43 | 13.24 | 16.99 | 16.49 | 18.03 | 16.36 | 21.80 | 19.10 | 26.27 | 26.27 | 29.85 | 29.85 | 30.91 | 30.91 | 34.47 | 34.47 |
| 70 | IC (Standard Air) | 8.04 | 7.44 | 11.43 | 10.51 | 14.81 | 15.60 | 17.34 | 15.81 | 18.39 | 16.58 | 22.22 | 19.47 | 26.75 | 26.75 | 30.23 | 30.23 | 31.27 | 31.27 | 34.80 | 34.80 |
| | KW | 1.86 | 2.01 | 2.15 | 2.25 | 2.27 | 2.36 | 2.46 | 2.51 | 2.53 | 2.65 | 2.82 | 2.94 | 2.97 | 3.07 | 3.13 | 3.20 | 3.25 | 3.41 | 3.41 | 3.80 |
| | Cap (KW) | 8.04 | 7.44 | 11.43 | 10.51 | 14.81 | 15.60 | 17.34 | 15.81 | 18.39 | 16.58 | 22.22 | 19.47 | 26.75 | 26.75 | 30.23 | 30.23 | 31.27 | 31.27 | 34.80 | 34.80 |
| 80 | IC (Standard Air) | 7.04 | 6.61 | 10.38 | 9.56 | 13.73 | 12.60 | 16.30 | 14.88 | 17.34 | 15.72 | 21.02 | 18.42 | 25.15 | 25.16 | 28.65 | 28.65 | 30.07 | 30.07 | 33.57 | 33.57 |
| | KW | 1.94 | 2.12 | 2.20 | 2.31 | 2.35 | 2.42 | 2.47 | 2.54 | 2.58 | 2.68 | 2.81 | 2.91 | 2.94 | 3.04 | 3.10 | 3.16 | 3.21 | 3.37 | 3.37 | 3.76 |
| | Cap (KW) | 7.30 | 6.75 | 10.68 | 9.82 | 14.05 | 12.90 | 16.62 | 15.15 | 17.68 | 16.04 | 21.41 | 18.76 | 25.64 | 25.64 | 29.21 | 29.21 | 30.52 | 30.52 | 34.04 | 34.04 |
| 1125 | IC (Standard Air) | 7.60 | 7.09 | 10.99 | 10.11 | 14.38 | 13.20 | 16.98 | 15.48 | 17.95 | 16.28 | 21.81 | 19.11 | 26.12 | 26.12 | 29.74 | 29.74 | 30.94 | 30.94 | 34.42 | 34.42 |
| | KW | 2.14 | 2.29 | 2.43 | 2.54 | 2.56 | 2.63 | 2.71 | 2.76 | 2.81 | 2.91 | 3.03 | 3.11 | 3.14 | 3.24 | 3.30 | 3.36 | 3.41 | 3.57 | 3.57 | 3.96 |
| | Cap (KW) | 7.60 | 7.09 | 10.99 | 10.11 | 14.38 | 13.20 | 16.98 | 15.48 | 17.95 | 16.28 | 21.81 | 19.11 | 26.12 | 26.12 | 29.74 | 29.74 | 30.94 | 30.94 | 34.42 | 34.42 |
| 875 | IC (Standard Air) | 6.76 | 8.25 | 10.05 | 9.25 | 13.35 | 12.26 | 15.87 | 14.47 | 16.91 | 18.33 | 20.60 | 18.05 | 24.65 | 24.65 | 27.91 | 27.91 | 29.39 | 29.39 | 32.99 | 32.99 |
| | KW | 2.12 | 2.31 | 2.30 | 2.31 | 2.38 | 2.42 | 2.47 | 2.54 | 2.58 | 2.68 | 2.79 | 2.88 | 2.91 | 3.01 | 3.07 | 3.13 | 3.18 | 3.34 | 3.34 | 3.73 |
| | Cap (KW) | 7.01 | 6.49 | 10.35 | 9.52 | 13.69 | 12.56 | 16.23 | 14.80 | 17.28 | 15.67 | 21.00 | 18.40 | 25.11 | 25.11 | 28.49 | 28.49 | 29.97 | 29.97 | 33.50 | 33.50 |
| 1125 | IC (Standard Air) | 7.35 | 6.80 | 10.71 | 9.86 | 14.06 | 12.91 | 16.61 | 15.15 | 17.68 | 16.03 | 21.42 | 18.77 | 25.57 | 25.57 | 29.10 | 29.10 | 30.50 | 30.50 | 33.96 | 33.96 |
| | KW | 2.32 | 2.48 | 2.57 | 2.68 | 2.71 | 2.79 | 2.86 | 2.91 | 2.99 | 3.03 | 3.11 | 3.16 | 3.21 | 3.26 | 3.32 | 3.37 | 3.42 | 3.58 | 3.58 | 3.97 |
| | Cap (KW) | 7.35 | 6.80 | 10.71 | 9.86 | 14.06 | 12.91 | 16.61 | 15.15 | 17.68 | 16.03 | 21.42 | 18.77 | 25.57 | 25.57 | 29.10 | 29.10 | 30.50 | 30.50 | 33.96 | 33.96 |

See Legend and Notes following.

PH4E30 Heating Extended Performance Table SI

| Return Air (° C db) | L/s | Air Temperature Entering Outdoor Coil (C) | | | | | | | | | | | | | | | | | | | |
|---------------------|----------|---|------|------|------|------|------|------|------|------|------|------|------|------|------|------|------|------|------|-------|-------|
| | | -23 | -18 | -12 | -8 | -7 | -1 | 4 | 8 | 10 | 16 | | | | | | | | | | |
| 16 | Cap (KW) | 2.14 | 1.98 | 3.13 | 2.88 | 4.12 | 3.76 | 8.17 | 7.46 | 5.18 | 4.70 | 6.27 | 5.49 | 7.54 | 7.54 | 8.58 | 8.58 | 8.94 | 8.94 | 9.97 | 9.97 |
| | KW | 1.77 | 1.94 | 2.10 | 2.22 | 2.24 | 2.34 | 2.44 | 2.52 | 2.56 | 2.68 | 2.85 | 2.98 | 3.01 | 3.09 | 3.12 | 3.21 | 3.27 | 3.31 | 3.47 | 3.47 |
| | Cap (KW) | 2.24 | 2.07 | 3.23 | 2.97 | 4.22 | 3.68 | 4.97 | 4.54 | 5.28 | 4.79 | 6.38 | 5.59 | 7.69 | 7.69 | 8.74 | 8.74 | 9.05 | 9.05 | 10.09 | 10.09 |
| 21 | Cap (KW) | 2.35 | 2.16 | 3.35 | 3.08 | 4.34 | 3.98 | 5.08 | 4.63 | 5.38 | 4.86 | 6.51 | 5.70 | 7.83 | 7.83 | 8.85 | 8.85 | 9.15 | 9.15 | 10.19 | 10.19 |
| | KW | 1.97 | 2.10 | 2.23 | 2.32 | 2.33 | 2.42 | 2.47 | 2.54 | 2.58 | 2.68 | 2.79 | 2.88 | 2.91 | 3.01 | 3.07 | 3.13 | 3.18 | 3.34 | 3.34 | 3.73 |
| | Cap (KW) | 2.06 | 1.91 | 3.04 | 2.80 | 4.02 | 3.69 | 4.70 | 4.35 | 5.08 | 4.60 | 6.15 | 5.39 | 7.37 | 7.37 | 8.39 | 8.39 | 8.80 | 8.80 | 9.83 | 9.83 |
| 27 | Cap (KW) | 2.14 | 1.98 | 3.13 | 2.88 | 4.11 | 3.76 | 4.87 | 4.44 | 5.18 | 4.70 | 6.27 | 5.49 | 7.51 | 7.51 | 8.55 | 8.55 | 8.94 | 8.94 | 9.97 | 9.97 |
| | KW | 2.03 | 2.19 | 2.35 | 2.47 | 2.49 | 2.57 | 2.63 | 2.68 | 2.72 | 2.81 | 2.86 | 2.91 | 2.99 | 3.04 | 3.09 | 3.14 | 3.19 | 3.24 | 3.29 | 3.34 |
| | Cap (KW) | 2.22 | 2.06 | 3.22 | 2.95 | 4.21 | 3.87 | 4.97 | 4.53 | 5.26 | 4.77 | 6.39 | 5.59 | 7.65 | 7.65 | 8.71 | 8.71 | 9.06 | 9.06 | 10.08 | 10.08 |
| 531 | Cap (KW) | 1.98 | 1.83 | 2.94 | 2.71 | 3.91 | 3.59 | 4.65 | 4.24 | 4.95 | 4.49 | 6.03 | 5.28 | 7.22 | 7.22 | 8.17 | 8.17 | 8.61 | 8.61 | 9.66 | 9.66 |
| | KW | 2.12 | 2.31 | 2.30 | 2.31 | 2.38 | 2.42 | 2.47 | 2.54 | 2.58 | 2.68 | 2.79 | 2.88 | 2.91 | 3.01 | 3.07 | 3.13 | 3.18 | 3.34 | 3.34 | 3.73 |
| | Cap (KW) | 2.05 | 1.90 | 3.03 | 2.79 | 4.01 | 3.68 | 4.75 | 4.33 | 5.06 | 4.59 | 6.15 | 5.39 | 7.35 | 7.35 | 8.34 | 8.34 | 8.77 | 8.77 | 9.81 | 9.81 |
| 531 | Cap (KW) | 2.15 | 1.99 | 3.14 | 2.88 | 4.12 | 3.78 | 4.86 | 4.43 | 5.18 | 4.69 | 6.27 | 5.49 | 7.49 | 7.49 | 8.52 | 8.52 | 8.93 | 8.93 | 9.94 | 9.94 |
| | KW | 2.32 | 2.48 | 2.57 | 2.68 | 2.71 | 2.79 | 2.86 | 2.91 | 2.99 | 3.03 | 3.11 | 3.16 | 3.21 | 3.26 | 3.32 | 3.37 | 3.42 | 3.58 | 3.58 | 3.97 |
| | Cap (KW) | 2.22 | 2.06 | 3.22 | 2.95 | 4.21 | 3.87 | 4.97 | 4.53 | 5.26 | 4.77 | 6.39 | 5.59 | 7.65 | 7.65 | 8.71 | 8.71 | 9.06 | 9.06 | 10.08 | 10.08 |

See Legend and Notes following.

PERFORMANCE DATA (CONT)

PH4E36 Cooling Extended Performance Table English

| Temp (°F) Outdoor Air Entering Condenser | Evaporator Air—CFM/BF | | | | | | | | | | | |
|--|-----------------------|------|------|------|-----------|------|------|------|-----------|------|----|----|
| | 1050/0.091 | | | | 1200/0.10 | | | | 1350/0.11 | | | |
| | 62 | 67 | 72 | 72 | 62 | 67 | 72 | 72 | 62 | 67 | 72 | 72 |
| 75 | TC | 36.2 | 39.9 | 43.6 | 37.0 | 40.7 | 44.2 | 37.2 | 41.2 | 44.6 | | |
| | SHC | 32.4 | 27.1 | 21.9 | 34.7 | 28.7 | 22.7 | 36.7 | 30.1 | 23.3 | | |
| | KW | 3.0 | 3.1 | 3.1 | 3.1 | 3.1 | 3.2 | 3.3 | 3.3 | 3.3 | | |
| 85 | TC | 34.3 | 38.3 | 42.1 | 35.2 | 38.8 | 42.7 | 35.9 | 39.3 | 43.0 | | |
| | SHC | 31.6 | 26.5 | 21.3 | 33.8 | 28.1 | 22.2 | 35.8 | 29.5 | 22.8 | | |
| | KW | 3.3 | 3.4 | 3.4 | 3.4 | 3.5 | 3.5 | 3.5 | 3.6 | 3.6 | | |
| 95 | TC | 32.4 | 36.4 | 40.3 | 33.2 | 36.9 | 40.8 | 34.2 | 37.2 | 41.1 | | |
| | SHC | 30.7 | 25.8 | 20.6 | 32.7 | 27.4 | 21.5 | 34.3 | 28.7 | 22.2 | | |
| | KW | 3.6 | 3.7 | 3.8 | 3.7 | 3.9 | 3.9 | 3.8 | 4.0 | 4.0 | | |
| 105 | TC | 30.4 | 34.2 | 38.1 | 31.4 | 34.8 | 38.6 | 32.3 | 35.1 | 38.8 | | |
| | SHC | 29.3 | 24.8 | 19.8 | 31.5 | 26.5 | 20.8 | 32.4 | 27.9 | 21.5 | | |
| | KW | 4.0 | 4.1 | 4.2 | 4.1 | 4.3 | 4.3 | 4.2 | 4.4 | 4.4 | | |
| 115 | TC | 28.7 | 32.0 | 35.8 | 29.7 | 32.5 | 36.2 | 30.8 | 32.8 | 36.4 | | |
| | SHC | 28.7 | 24.0 | 19.0 | 29.8 | 25.6 | 19.9 | 30.9 | 27.1 | 20.6 | | |
| | KW | 4.4 | 4.6 | 4.6 | 4.5 | 4.7 | 4.7 | 4.6 | 4.8 | 4.9 | | |
| 125 | TC | 26.9 | 29.7 | 33.2 | 28.1 | 30.1 | 33.6 | 29.0 | 30.3 | 33.7 | | |
| | SHC | 27.0 | 23.1 | 18.1 | 28.2 | 24.7 | 19.0 | 29.1 | 26.1 | 19.7 | | |
| | KW | 4.9 | 5.0 | 5.1 | 5.0 | 5.1 | 5.2 | 5.1 | 5.3 | 5.3 | | |

See Legend and Notes following.

PH4E36 Cooling Extended Performance Table SI

| Temp (°C) Outdoor Air Entering Condenser | Evaporator Air—L/s—BF | | | | | | | | | | | |
|--|-----------------------|------|------|------|----------|------|------|------|----------|------|----|----|
| | 495/0.91 | | | | 566/0.10 | | | | 637/0.11 | | | |
| | 17 | 19 | 22 | 22 | 17 | 19 | 22 | 22 | 17 | 19 | 22 | 22 |
| 24 | TC | 10.5 | 11.6 | 12.3 | 10.8 | 11.7 | 12.3 | 10.9 | 11.8 | 12.3 | | |
| | SHC | 9.3 | 7.8 | 6.2 | 9.8 | 8.1 | 6.3 | 10.3 | 8.4 | 6.4 | | |
| | KW | 3.0 | 3.0 | 3.0 | 3.1 | 3.1 | 3.2 | 3.3 | 3.3 | 3.3 | | |
| 29 | TC | 10.1 | 11.1 | 12.0 | 10.3 | 11.3 | 12.1 | 10.5 | 11.3 | 12.1 | | |
| | SHC | 9.1 | 7.6 | 6.1 | 9.6 | 8.0 | 6.2 | 10.1 | 8.3 | 6.3 | | |
| | KW | 3.3 | 3.4 | 3.4 | 3.4 | 3.5 | 3.5 | 3.6 | 3.7 | 3.7 | | |
| 35 | TC | 9.6 | 10.6 | 11.6 | 9.8 | 10.7 | 11.6 | 9.9 | 10.8 | 11.6 | | |
| | SHC | 8.9 | 7.4 | 5.9 | 9.4 | 7.8 | 6.1 | 9.9 | 8.1 | 6.1 | | |
| | KW | 3.6 | 3.7 | 3.7 | 3.8 | 3.9 | 3.9 | 3.9 | 4.0 | 4.0 | | |
| 41 | TC | 9.1 | 10.1 | 11.0 | 9.3 | 10.2 | 11.1 | 9.6 | 10.2 | 11.1 | | |
| | SHC | 8.7 | 7.2 | 5.7 | 9.1 | 7.6 | 5.9 | 9.5 | 7.9 | 6.0 | | |
| | KW | 4.0 | 4.1 | 4.1 | 4.1 | 4.3 | 4.3 | 4.2 | 4.4 | 4.4 | | |
| 46 | TC | 8.6 | 9.5 | 10.4 | 8.8 | 9.6 | 10.4 | 9.1 | 9.6 | 10.3 | | |
| | SHC | 8.3 | 6.9 | 5.5 | 8.8 | 7.3 | 5.6 | 9.1 | 7.6 | 5.7 | | |
| | KW | 4.4 | 4.5 | 4.5 | 4.5 | 4.7 | 4.7 | 4.7 | 4.8 | 4.8 | | |
| 52 | TC | 8.1 | 8.8 | 9.6 | 8.9 | 9.9 | 9.6 | 8.5 | 8.9 | 9.5 | | |
| | SHC | 8.0 | 6.7 | 5.2 | 8.5 | 7.0 | 5.3 | 8.5 | 7.4 | 5.3 | | |
| | KW | 4.9 | 5.0 | 5.0 | 5.3 | 5.1 | 5.1 | 5.1 | 5.2 | 5.2 | | |

See Legend and Notes following.

PERFORMANCE DATA (CONT)

PH4E36 Heating Extended Performance Table English

| Return Air (°F db) | | Air Temperature Entering Outdoor Coil (F) | | | | | | | | | | | | | | | | | | | | | | | | | |
|--------------------|-------|---|-------|-------|-------|-------|-------|-------|-------|-------|-------|--------------------|-------|---|-------|-------|-------|-------|-------|-------|-------|-------|-------|-------|-------|-------|--|
| CFM | | -10 | 0 | 10 | 17 | 20 | 30 | 40 | 47 | 50 | 60 | Return Air (°C db) | | Air Temperature Entering Outdoor Coil (C) | | | | | | | | | | | | | |
| 60 | 70 | 80 | 1050 | 1200 | 1350 | 1050 | 1200 | 1350 | 1050 | 1200 | 1350 | 1050 | 1200 | 1350 | 1050 | 1200 | 1350 | 1050 | 1200 | 1350 | 1050 | 1200 | 1350 | | | | |
| TC | TC | TC | TC | TC | TC | TC | TC | TC | TC | TC | TC | TC | TC | TC | TC | TC | TC | TC | TC | TC | TC | TC | TC | TC | | | |
| KW | KW | KW | KW | KW | KW | KW | KW | KW | KW | KW | KW | KW | KW | KW | KW | KW | KW | KW | KW | KW | KW | KW | KW | KW | KW | | |
| 9.65 | 9.85 | 10.05 | 10.25 | 10.45 | 10.65 | 10.85 | 11.05 | 11.25 | 11.45 | 11.65 | 11.85 | 12.05 | 12.25 | 12.45 | 12.65 | 12.85 | 13.05 | 13.25 | 13.45 | 13.65 | 13.85 | 14.05 | 14.25 | 14.45 | 14.65 | | |
| 2.04 | 2.15 | 2.26 | 2.35 | 2.44 | 2.53 | 2.61 | 2.69 | 2.77 | 2.84 | 2.91 | 2.97 | 3.03 | 3.08 | 3.14 | 3.19 | 3.24 | 3.28 | 3.33 | 3.37 | 3.41 | 3.45 | 3.48 | 3.51 | 3.54 | 3.57 | 3.60 | |
| 10.7 | 11.21 | 11.71 | 12.21 | 12.71 | 13.21 | 13.71 | 14.21 | 14.71 | 15.21 | 15.71 | 16.21 | 16.71 | 17.21 | 17.71 | 18.21 | 18.71 | 19.21 | 19.71 | 20.21 | 20.71 | 21.21 | 21.71 | 22.21 | 22.71 | 23.21 | 23.71 | |
| 2.15 | 2.31 | 2.48 | 2.64 | 2.79 | 2.94 | 3.09 | 3.24 | 3.39 | 3.54 | 3.69 | 3.84 | 3.99 | 4.14 | 4.29 | 4.44 | 4.59 | 4.74 | 4.89 | 5.04 | 5.19 | 5.34 | 5.49 | 5.64 | 5.79 | 5.94 | 6.09 | |
| 11.21 | 11.71 | 12.21 | 12.71 | 13.21 | 13.71 | 14.21 | 14.71 | 15.21 | 15.71 | 16.21 | 16.71 | 17.21 | 17.71 | 18.21 | 18.71 | 19.21 | 19.71 | 20.21 | 20.71 | 21.21 | 21.71 | 22.21 | 22.71 | 23.21 | 23.71 | 24.21 | |
| 2.35 | 2.53 | 2.71 | 2.89 | 3.07 | 3.25 | 3.43 | 3.61 | 3.79 | 3.97 | 4.15 | 4.33 | 4.51 | 4.69 | 4.87 | 5.05 | 5.23 | 5.41 | 5.59 | 5.77 | 5.95 | 6.13 | 6.31 | 6.49 | 6.67 | 6.85 | 7.03 | |
| 12.71 | 13.21 | 13.71 | 14.21 | 14.71 | 15.21 | 15.71 | 16.21 | 16.71 | 17.21 | 17.71 | 18.21 | 18.71 | 19.21 | 19.71 | 20.21 | 20.71 | 21.21 | 21.71 | 22.21 | 22.71 | 23.21 | 23.71 | 24.21 | 24.71 | 25.21 | 25.71 | |
| 2.48 | 2.67 | 2.86 | 3.05 | 3.24 | 3.43 | 3.62 | 3.81 | 4.00 | 4.19 | 4.38 | 4.57 | 4.76 | 4.95 | 5.14 | 5.33 | 5.52 | 5.71 | 5.90 | 6.09 | 6.28 | 6.47 | 6.66 | 6.85 | 7.04 | 7.23 | 7.42 | |
| 13.21 | 13.71 | 14.21 | 14.71 | 15.21 | 15.71 | 16.21 | 16.71 | 17.21 | 17.71 | 18.21 | 18.71 | 19.21 | 19.71 | 20.21 | 20.71 | 21.21 | 21.71 | 22.21 | 22.71 | 23.21 | 23.71 | 24.21 | 24.71 | 25.21 | 25.71 | 26.21 | |
| 2.61 | 2.81 | 3.01 | 3.21 | 3.41 | 3.61 | 3.81 | 4.01 | 4.21 | 4.41 | 4.61 | 4.81 | 5.01 | 5.21 | 5.41 | 5.61 | 5.81 | 6.01 | 6.21 | 6.41 | 6.61 | 6.81 | 7.01 | 7.21 | 7.41 | 7.61 | 7.81 | |
| 14.71 | 15.21 | 15.71 | 16.21 | 16.71 | 17.21 | 17.71 | 18.21 | 18.71 | 19.21 | 19.71 | 20.21 | 20.71 | 21.21 | 21.71 | 22.21 | 22.71 | 23.21 | 23.71 | 24.21 | 24.71 | 25.21 | 25.71 | 26.21 | 26.71 | 27.21 | 27.71 | |
| 2.73 | 2.94 | 3.15 | 3.36 | 3.57 | 3.78 | 3.99 | 4.20 | 4.41 | 4.62 | 4.83 | 5.04 | 5.25 | 5.46 | 5.67 | 5.88 | 6.09 | 6.30 | 6.51 | 6.72 | 6.93 | 7.14 | 7.35 | 7.56 | 7.77 | 7.98 | | |
| 15.21 | 15.71 | 16.21 | 16.71 | 17.21 | 17.71 | 18.21 | 18.71 | 19.21 | 19.71 | 20.21 | 20.71 | 21.21 | 21.71 | 22.21 | 22.71 | 23.21 | 23.71 | 24.21 | 24.71 | 25.21 | 25.71 | 26.21 | 26.71 | 27.21 | 27.71 | 28.21 | |
| 2.86 | 3.07 | 3.28 | 3.49 | 3.70 | 3.91 | 4.12 | 4.33 | 4.54 | 4.75 | 4.96 | 5.17 | 5.38 | 5.59 | 5.80 | 6.01 | 6.22 | 6.43 | 6.64 | 6.85 | 7.06 | 7.27 | 7.48 | 7.69 | 7.90 | 8.11 | | |
| 15.71 | 16.21 | 16.71 | 17.21 | 17.71 | 18.21 | 18.71 | 19.21 | 19.71 | 20.21 | 20.71 | 21.21 | 21.71 | 22.21 | 22.71 | 23.21 | 23.71 | 24.21 | 24.71 | 25.21 | 25.71 | 26.21 | 26.71 | 27.21 | 27.71 | 28.21 | 28.71 | |
| 2.99 | 3.21 | 3.43 | 3.65 | 3.87 | 4.09 | 4.31 | 4.53 | 4.75 | 4.97 | 5.19 | 5.41 | 5.63 | 5.85 | 6.07 | 6.29 | 6.51 | 6.73 | 6.95 | 7.17 | 7.39 | 7.61 | 7.83 | 8.05 | 8.27 | 8.49 | | |
| 16.21 | 16.71 | 17.21 | 17.71 | 18.21 | 18.71 | 19.21 | 19.71 | 20.21 | 20.71 | 21.21 | 21.71 | 22.21 | 22.71 | 23.21 | 23.71 | 24.21 | 24.71 | 25.21 | 25.71 | 26.21 | 26.71 | 27.21 | 27.71 | 28.21 | 28.71 | 29.21 | |
| 3.11 | 3.34 | 3.57 | 3.80 | 4.03 | 4.26 | 4.49 | 4.72 | 4.95 | 5.18 | 5.41 | 5.64 | 5.87 | 6.10 | 6.33 | 6.56 | 6.79 | 7.02 | 7.25 | 7.48 | 7.71 | 7.94 | 8.17 | 8.40 | 8.63 | 8.86 | | |
| 16.71 | 17.21 | 17.71 | 18.21 | 18.71 | 19.21 | 19.71 | 20.21 | 20.71 | 21.21 | 21.71 | 22.21 | 22.71 | 23.21 | 23.71 | 24.21 | 24.71 | 25.21 | 25.71 | 26.21 | 26.71 | 27.21 | 27.71 | 28.21 | 28.71 | 29.21 | 29.71 | |
| 3.24 | 3.48 | 3.72 | 3.96 | 4.20 | 4.44 | 4.68 | 4.92 | 5.16 | 5.40 | 5.64 | 5.88 | 6.12 | 6.36 | 6.60 | 6.84 | 7.08 | 7.32 | 7.56 | 7.80 | 8.04 | 8.28 | 8.52 | 8.76 | 9.00 | 9.24 | | |
| 17.21 | 17.71 | 18.21 | 18.71 | 19.21 | 19.71 | 20.21 | 20.71 | 21.21 | 21.71 | 22.21 | 22.71 | 23.21 | 23.71 | 24.21 | 24.71 | 25.21 | 25.71 | 26.21 | 26.71 | 27.21 | 27.71 | 28.21 | 28.71 | 29.21 | 29.71 | 30.21 | |
| 3.37 | 3.62 | 3.87 | 4.12 | 4.37 | 4.62 | 4.87 | 5.12 | 5.37 | 5.62 | 5.87 | 6.12 | 6.37 | 6.62 | 6.87 | 7.12 | 7.37 | 7.62 | 7.87 | 8.12 | 8.37 | 8.62 | 8.87 | 9.12 | 9.37 | 9.62 | | |
| 17.71 | 18.21 | 18.71 | 19.21 | 19.71 | 20.21 | 20.71 | 21.21 | 21.71 | 22.21 | 22.71 | 23.21 | 23.71 | 24.21 | 24.71 | 25.21 | 25.71 | 26.21 | 26.71 | 27.21 | 27.71 | 28.21 | 28.71 | 29.21 | 29.71 | 30.21 | 30.71 | |
| 3.50 | 3.76 | 4.02 | 4.28 | 4.54 | 4.80 | 5.06 | 5.32 | 5.58 | 5.84 | 6.10 | 6.36 | 6.62 | 6.88 | 7.14 | 7.40 | 7.66 | 7.92 | 8.18 | 8.44 | 8.70 | 8.96 | 9.22 | 9.48 | 9.74 | 10.00 | | |
| 18.21 | 18.71 | 19.21 | 19.71 | 20.21 | 20.71 | 21.21 | 21.71 | 22.21 | 22.71 | 23.21 | 23.71 | 24.21 | 24.71 | 25.21 | 25.71 | 26.21 | 26.71 | 27.21 | 27.71 | 28.21 | 28.71 | 29.21 | 29.71 | 30.21 | 30.71 | 31.21 | |
| 3.63 | 3.90 | 4.17 | 4.44 | 4.71 | 4.98 | 5.25 | 5.52 | 5.79 | 6.06 | 6.33 | 6.60 | 6.87 | 7.14 | 7.41 | 7.68 | 7.95 | 8.22 | 8.49 | 8.76 | 9.03 | 9.30 | 9.57 | 9.84 | 10.11 | 10.38 | | |
| 18.71 | 19.21 | 19.71 | 20.21 | 20.71 | 21.21 | 21.71 | 22.21 | 22.71 | 23.21 | 23.71 | 24.21 | 24.71 | 25.21 | 25.71 | 26.21 | 26.71 | 27.21 | 27.71 | 28.21 | 28.71 | 29.21 | 29.71 | 30.21 | 30.71 | 31.21 | 31.71 | |
| 3.76 | 4.04 | 4.32 | 4.60 | 4.88 | 5.16 | 5.44 | 5.72 | 6.00 | 6.28 | 6.56 | 6.84 | 7.12 | 7.40 | 7.68 | 7.96 | 8.24 | 8.52 | 8.80 | 9.08 | 9.36 | 9.64 | 9.92 | 10.20 | 10.48 | 10.76 | | |
| 19.21 | 19.71 | 20.21 | 20.71 | 21.21 | 21.71 | 22.21 | 22.71 | 23.21 | 23.71 | 24.21 | 24.71 | 25.21 | 25.71 | 26.21 | 26.71 | 27.21 | 27.71 | 28.21 | 28.71 | 29.21 | 29.71 | 30.21 | 30.71 | 31.21 | 31.71 | 32.21 | |
| 3.89 | 4.18 | 4.47 | 4.76 | 5.05 | 5.34 | 5.63 | 5.92 | 6.21 | 6.50 | 6.79 | 7.08 | 7.37 | 7.66 | 7.95 | 8.24 | 8.53 | 8.82 | 9.11 | 9.40 | 9.69 | 9.98 | 10.27 | 10.56 | 10.85 | 11.14 | | |
| 19.71 | 20.21 | 20.71 | 21.21 | 21.71 | 22.21 | 22.71 | 23.21 | 23.71 | 24.21 | 24.71 | 25.21 | 25.71 | 26.21 | 26.71 | 27.21 | 27.71 | 28.21 | 28.71 | 29.21 | 29.71 | 30.21 | 30.71 | 31.21 | 31.71 | 32.21 | 32.71 | |
| 4.02 | 4.32 | 4.62 | 4.92 | 5.22 | 5.52 | 5.82 | 6.12 | 6.42 | 6.72 | 7.02 | 7.32 | 7.62 | 7.92 | 8.22 | 8.52 | 8.82 | 9.12 | 9.42 | 9.72 | 10.02 | 10.32 | 10.62 | 10.92 | 11.22 | 11.52 | | |
| 20.21 | 20.71 | 21.21 | 21.71 | 22.21 | 22.71 | 23.21 | 23.71 | 24.21 | 24.71 | 25.21 | 25.71 | 26.21 | 26.71 | 27.21 | 27.71 | 28.21 | 28.71 | 29.21 | 29.71 | 30.21 | 30.71 | 31.21 | 31.71 | 32.21 | 32.71 | 33.21 | |
| 4.15 | 4.46 | 4.77 | 5.08 | 5.39 | 5.70 | 6.01 | 6.32 | 6.63 | 6.94 | 7.25 | 7.56 | 7.87 | 8.18 | 8.49 | 8.80 | 9.11 | 9.42 | 9.73 | 10.04 | 10.35 | 10.66 | 10.97 | 11.28 | 11.59 | 11.90 | | |
| 20.71 | 21.21 | 21.71 | 22.21 | 22.71 | 23.21 | 23.71 | 24.21 | 24.71 | 25.21 | 25.71 | 26.21 | 26.71 | 27.21 | 27.71 | 28.21 | 28.71 | 29.21 | 29.71 | 30.21 | 30.71 | 31.21 | 31.71 | 32.21 | 32.71 | 33.21 | 33.71 | |
| 4.28 | 4.60 | 4.92 | 5.24 | 5.56 | 5.88 | 6.20 | 6.52 | 6.84 | 7.16 | 7.48 | 7.80 | 8.12 | 8.44 | 8.76 | 9.08 | 9.40 | 9.72 | 10.04 | 10.36 | 10.68 | 11.00 | 11.32 | 11.64 | 11.96 | 12.28 | | |
| 21.21 | 21.71 | 22.21 | 22.71 | 23.21 | 23.71 | 24.21 | 24.71 | 25.21 | 25.71 | 26.21 | 26.71 | 27.21 | 27.71 | 28.21 | 28.71 | 29.21 | 29.71 | 30.21 | 30.71 | 31.21 | 31.71 | 32.21 | 32.71 | 33.21 | 33.71 | 34.21 | |
| 4.41 | 4.74 | 5.07 | 5.40 | 5.73 | 6.06 | 6.39 | 6.72 | 7.05 | 7.38 | 7.71 | 8.04 | 8.37 | 8.70 | 9.03 | 9.36 | 9.69 | 10.02 | 10.35 | 10.68 | 11.01 | 11.34 | 11.67 | 12.00 | 12.33 | 12.66 | | |
| 21.71 | 22.21 | 22.71 | 23.21 | 23.71 | 24.21 | 24.71 | 25.21 | 25.71 | 26.21 | 26.71 | 27.21 | 27.71 | 28.21 | 28.71 | 29.21 | 29.71 | 30.21 | 30.71 | 31.21 | 31.71 | 32.21 | 32.71 | 33.21 | 33.71 | 34.21 | 34.71 | |
| 4.54 | 4.88 | 5.22 | 5.56 | 5.90 | 6.24 | 6.58 | 6.92 | 7.26 | 7.60 | 7.94 | 8.28 | 8.62 | 8.96 | 9.30 | 9.64 | 9.98 | 10.32 | 10.66 | 11.00 | 11.34 | 11.68 | 12.02 | | | | | |

PERFORMANCE DATA (CONT)

PH4E48 Cooling Extended Performance Table English

| Temp (°F) Outdoor Air Entering Condenser | Evaporator Air—CFM/BF | | | | | | | | | | | | | |
|--|-----------------------|------|------|------|------|------|------------|------|------|------|------|------|-----------|--|
| | 1400/0.091 | | | | | | 1600/0.098 | | | | | | 1800/0.12 | |
| | 62 | 67 | 72 | 62 | 67 | 72 | 62 | 67 | 72 | 62 | 67 | 72 | | |
| 75 | TC | 46.7 | 52.0 | 56.3 | 47.6 | 52.6 | 56.7 | 48.4 | 52.8 | 56.6 | 56.6 | 56.6 | | |
| | SHC | 42.5 | 35.8 | 28.0 | 45.0 | 37.6 | 28.7 | 46.8 | 39.0 | 29.1 | 29.1 | 29.1 | | |
| | KW | 4.3 | 4.4 | 4.4 | 4.4 | 4.6 | 4.6 | 4.6 | 4.9 | 4.9 | 4.9 | 4.9 | | |
| 85 | TC | 44.7 | 49.5 | 54.3 | 45.6 | 50.3 | 54.5 | 46.3 | 50.5 | 54.6 | 54.6 | 54.6 | | |
| | SHC | 41.5 | 34.5 | 27.3 | 43.8 | 36.6 | 28.0 | 45.7 | 38.4 | 28.5 | 28.5 | 28.5 | | |
| | KW | 4.7 | 4.8 | 4.9 | 4.8 | 5.1 | 5.1 | 5.0 | 5.3 | 5.3 | 5.3 | 5.3 | | |
| 95 | TC | 42.7 | 47.1 | 51.9 | 43.6 | 47.9 | 52.2 | 44.6 | 48.0 | 52.2 | 52.2 | 52.2 | | |
| | SHC | 40.4 | 33.7 | 26.4 | 42.4 | 35.7 | 27.3 | 44.0 | 37.3 | 27.8 | 27.8 | 27.8 | | |
| | KW | 5.1 | 5.3 | 5.3 | 5.3 | 5.5 | 5.5 | 5.5 | 5.8 | 5.8 | 5.8 | 5.8 | | |
| 105 | TC | 40.6 | 44.6 | 49.4 | 41.6 | 45.0 | 49.6 | 42.6 | 45.4 | 49.5 | 49.5 | 49.5 | | |
| | SHC | 39.1 | 32.6 | 25.5 | 41.1 | 34.4 | 26.3 | 42.0 | 36.3 | 26.9 | 26.9 | 26.9 | | |
| | KW | 5.6 | 5.8 | 5.8 | 5.7 | 6.0 | 6.0 | 6.0 | 6.3 | 6.3 | 6.3 | 6.3 | | |
| 115 | TC | 38.6 | 41.9 | 46.6 | 39.7 | 42.2 | 46.6 | 40.5 | 42.4 | 46.5 | 46.5 | 46.5 | | |
| | SHC | 37.6 | 31.6 | 24.5 | 39.2 | 33.3 | 25.3 | 40.0 | 35.0 | 25.8 | 25.8 | 25.8 | | |
| | KW | 6.1 | 6.3 | 6.4 | 6.3 | 6.6 | 6.6 | 6.5 | 6.8 | 6.8 | 6.8 | 6.8 | | |

See Legend and Notes following.

PH4E48 Cooling Extended Performance Table SI

| Temp (°C) Outdoor Air Entering Condenser | Evaporator Air—L/s—BF | | | | | | | | | | | | | |
|--|-----------------------|------|------|------|------|------|-----------|------|------|------|------|------|----------|--|
| | 661/0.091 | | | | | | 755/0.098 | | | | | | 850/0.12 | |
| | 17 | 19 | 22 | 17 | 19 | 22 | 17 | 19 | 22 | 17 | 19 | 22 | | |
| 24 | TC | 13.9 | 15.4 | 16.5 | 14.5 | 15.7 | 16.7 | 14.8 | 16.0 | 16.8 | 16.8 | 16.8 | | |
| | SHC | 12.5 | 10.3 | 8.0 | 13.5 | 10.9 | 8.3 | 14.5 | 11.5 | 8.6 | 8.6 | 8.6 | | |
| | KW | 4.4 | 4.4 | 4.5 | 4.4 | 4.5 | 4.5 | 4.4 | 4.5 | 4.5 | 4.5 | 4.5 | | |
| 29 | TC | 13.2 | 14.8 | 16.0 | 13.7 | 15.2 | 16.3 | 14.1 | 15.5 | 16.5 | 16.5 | 16.5 | | |
| | SHC | 12.1 | 10.1 | 7.9 | 13.1 | 10.9 | 8.3 | 14.1 | 11.5 | 8.6 | 8.6 | 8.6 | | |
| | KW | 4.8 | 4.9 | 4.9 | 4.8 | 4.9 | 5.0 | 4.8 | 4.9 | 5.0 | 5.0 | 5.0 | | |
| 35 | TC | 12.5 | 14.1 | 15.5 | 12.9 | 14.4 | 15.8 | 13.4 | 14.7 | 16.0 | 16.0 | 16.0 | | |
| | SHC | 11.7 | 9.8 | 7.7 | 12.7 | 10.6 | 8.1 | 13.4 | 11.3 | 8.5 | 8.5 | 8.5 | | |
| | KW | 5.2 | 5.3 | 5.4 | 5.3 | 5.3 | 5.4 | 5.3 | 5.4 | 5.5 | 5.5 | 5.5 | | |
| 41 | TC | 11.7 | 13.2 | 14.8 | 12.2 | 13.6 | 15.1 | 12.8 | 13.9 | 15.3 | 15.3 | 15.3 | | |
| | SHC | 11.4 | 9.5 | 7.5 | 12.2 | 10.3 | 7.9 | 12.8 | 11.0 | 8.3 | 8.3 | 8.3 | | |
| | KW | 5.7 | 5.9 | 5.9 | 5.8 | 5.9 | 5.9 | 5.8 | 5.9 | 6.0 | 6.0 | 6.0 | | |
| 46 | TC | 10.8 | 12.1 | 13.8 | 11.4 | 12.5 | 14.1 | 11.9 | 12.7 | 14.4 | 14.4 | 14.4 | | |
| | SHC | 10.8 | 9.0 | 7.1 | 11.4 | 9.8 | 7.6 | 11.9 | 10.5 | 8.0 | 8.0 | 8.0 | | |
| | KW | 6.4 | 6.5 | 6.6 | 6.5 | 6.6 | 6.7 | 6.5 | 6.6 | 6.7 | 6.7 | 6.7 | | |

See Legend and Notes following.

PERFORMANCE DATA (CONT)

PH4E48 Heating Extended Performance Table English

| Return Air (°F db) | CFM | | Air Temperature Entering Outdoor Coil (°F) | | | | | | | | | | | | | | | | | | | |
|--------------------|--------------|----------------|--|-------|-------|-------|-------|-------|-------|-------|-------|-------|-------|-------|-------|-------|-------|-------|-------|-------|-------|-------|
| | Standard Air | (Standard Air) | -10 | 0 | 10 | 17 | 20 | 30 | 40 | 47 | 50 | 60 | | | | | | | | | | |
| 60 | 1400 | TC | 24.58 | 22.78 | 28.22 | 25.97 | 31.86 | 21.67 | 27.90 | 25.44 | 35.50 | 32.20 | 39.14 | 34.30 | 42.25 | 45.83 | 45.83 | 46.85 | 46.85 | 49.68 | 49.68 | |
| | | RW | 2.99 | 2.99 | 3.18 | 3.18 | 3.36 | 3.36 | 3.49 | 3.49 | 3.55 | 3.55 | 3.73 | 3.73 | 3.74 | 3.74 | 3.93 | 3.93 | 3.98 | 3.98 | 4.16 | 4.16 |
| | 1600 | TC | 29.06 | 26.88 | 32.02 | 29.48 | 34.98 | 32.11 | 37.05 | 33.78 | 37.94 | 34.41 | 40.90 | 35.83 | 43.54 | 43.54 | 46.19 | 46.19 | 47.10 | 47.10 | 49.53 | 49.53 |
| 1800 | | RW | 3.31 | 3.31 | 3.44 | 3.44 | 3.58 | 3.58 | 3.67 | 3.67 | 3.71 | 3.71 | 3.85 | 3.85 | 3.85 | 3.85 | 3.98 | 3.98 | 4.02 | 4.02 | 4.16 | 4.16 |
| | 1400 | TC | 32.51 | 30.07 | 34.99 | 32.19 | 37.46 | 34.38 | 39.19 | 35.73 | 39.94 | 36.22 | 42.41 | 37.15 | 44.68 | 44.68 | 46.76 | 46.76 | 47.58 | 47.58 | 49.67 | 49.67 |
| | | RW | 3.57 | 3.57 | 3.68 | 3.68 | 3.79 | 3.79 | 3.87 | 3.87 | 3.91 | 3.91 | 4.02 | 4.02 | 4.02 | 4.02 | 4.13 | 4.13 | 4.16 | 4.16 | 4.27 | 4.27 |
| 70 | 1400 | TC | 22.66 | 20.95 | 27.21 | 25.03 | 31.75 | 29.14 | 34.94 | 31.85 | 36.30 | 32.92 | 40.85 | 35.79 | 45.40 | 45.40 | 45.79 | 45.79 | 47.27 | 47.27 | 50.87 | 50.87 |
| | | RW | 3.63 | 3.63 | 3.80 | 3.80 | 3.98 | 3.98 | 4.10 | 4.10 | 4.15 | 4.15 | 4.33 | 4.33 | 4.50 | 4.50 | 4.36 | 4.36 | 4.42 | 4.42 | 4.67 | 4.67 |
| | 1600 | TC | 21.97 | 20.32 | 26.19 | 24.10 | 30.41 | 27.91 | 33.37 | 30.42 | 34.63 | 31.41 | 38.85 | 34.04 | 42.32 | 42.32 | 46.72 | 46.72 | 47.91 | 47.91 | 50.97 | 50.97 |
| 80 | | RW | 3.28 | 3.28 | 3.50 | 3.50 | 3.73 | 3.73 | 3.88 | 3.88 | 3.95 | 3.95 | 4.17 | 4.17 | 4.18 | 4.18 | 4.41 | 4.41 | 4.49 | 4.49 | 4.87 | 4.87 |
| | 1400 | TC | 27.11 | 26.07 | 30.59 | 28.15 | 34.07 | 31.27 | 36.51 | 33.28 | 37.55 | 34.06 | 41.03 | 35.95 | 43.79 | 43.79 | 47.58 | 47.58 | 48.61 | 48.61 | 50.94 | 50.94 |
| | | RW | 3.83 | 3.83 | 3.97 | 3.97 | 4.11 | 4.11 | 4.21 | 4.21 | 4.26 | 4.26 | 4.40 | 4.40 | 4.38 | 4.38 | 4.58 | 4.58 | 4.64 | 4.64 | 4.87 | 4.87 |
| 1600 | 1400 | TC | 5.38 | 4.97 | 12.24 | 11.25 | 19.10 | 17.83 | 23.90 | 21.79 | 25.96 | 23.59 | 32.82 | 28.75 | 39.69 | 39.69 | 44.49 | 44.49 | 46.55 | 46.55 | 53.41 | 53.41 |
| | | RW | 4.04 | 4.04 | 4.20 | 4.20 | 4.37 | 4.37 | 4.49 | 4.49 | 4.54 | 4.54 | 4.70 | 4.70 | 4.87 | 4.87 | 4.72 | 4.72 | 4.83 | 4.83 | 5.00 | 5.00 |
| | 1600 | TC | 10.31 | 9.63 | 17.30 | 15.92 | 24.30 | 22.30 | 29.20 | 28.62 | 31.30 | 28.38 | 38.29 | 33.55 | 45.29 | 45.29 | 45.90 | 45.90 | 48.15 | 48.15 | 53.71 | 53.71 |
| 1800 | | RW | 4.09 | 4.09 | 4.31 | 4.31 | 4.53 | 4.53 | 4.68 | 4.68 | 4.75 | 4.75 | 4.96 | 4.96 | 5.18 | 5.18 | 5.34 | 5.34 | 4.96 | 4.96 | 5.18 | 5.18 |
| | 1400 | TC | 23.26 | 21.51 | 27.99 | 25.76 | 32.73 | 30.04 | 36.05 | 32.87 | 37.47 | 34.08 | 42.21 | 36.98 | 46.95 | 46.95 | 47.32 | 47.32 | 49.03 | 49.03 | 52.55 | 52.55 |
| | | RW | 4.35 | 4.35 | 4.52 | 4.52 | 4.68 | 4.68 | 4.80 | 4.80 | 4.85 | 4.85 | 5.02 | 5.02 | 5.18 | 5.18 | 5.04 | 5.04 | 5.11 | 5.11 | 5.34 | 5.34 |

See Legend and Notes following.

PH4E48 Heating Extended Performance Table SI

| Return Air (°C db) | L/s | Air Temperature Entering Outdoor Coil (°C) | | | | | | | | | | | | | | | | | | | | |
|--------------------|------|--|------|------|-------|------|-------|-------|-------|-------|-------|-------|-------|-------|-------|-------|-------|-------|-------|-------|-------|-------|
| | | (Standard Air) | -23 | -18 | -12 | -8 | -7 | -1 | 4 | 8 | 10 | 16 | | | | | | | | | | |
| 16 | 661 | Cap (kW) | 7.20 | 6.88 | 8.26 | 7.60 | 9.33 | 6.56 | 8.17 | 7.46 | 10.40 | 8.43 | 11.46 | 10.04 | 12.37 | 12.37 | 13.42 | 13.42 | 13.72 | 13.72 | 14.55 | 14.55 |
| | | KW | 2.89 | 2.89 | 3.18 | 3.18 | 3.36 | 3.36 | 3.49 | 3.49 | 3.55 | 3.55 | 3.73 | 3.73 | 3.74 | 3.74 | 3.93 | 3.93 | 3.98 | 3.98 | 4.16 | 4.16 |
| | 755 | Cap (kW) | 8.51 | 7.87 | 9.38 | 8.63 | 10.24 | 9.40 | 10.85 | 9.89 | 11.11 | 10.07 | 11.97 | 10.49 | 12.75 | 12.75 | 13.53 | 13.53 | 13.79 | 13.79 | 14.50 | 14.50 |
| 21 | | KW | 3.81 | 3.81 | 3.44 | 3.44 | 3.58 | 3.58 | 3.67 | 3.67 | 3.71 | 3.71 | 3.85 | 3.85 | 3.85 | 3.85 | 3.98 | 3.98 | 4.02 | 4.02 | 4.16 | 4.16 |
| | 850 | Cap (kW) | 9.52 | 6.80 | 10.24 | 9.43 | 10.97 | 10.97 | 11.48 | 10.48 | 11.69 | 10.60 | 12.42 | 10.88 | 13.08 | 13.08 | 13.69 | 13.69 | 13.93 | 13.93 | 14.54 | 14.54 |
| | | KW | 3.57 | 3.57 | 3.68 | 3.68 | 3.79 | 3.79 | 3.87 | 3.87 | 3.91 | 3.91 | 4.02 | 4.02 | 4.02 | 4.02 | 4.13 | 4.13 | 4.16 | 4.16 | 4.27 | 4.27 |
| 27 | 661 | Cap (kW) | 6.63 | 6.14 | 7.97 | 7.33 | 9.30 | 8.53 | 10.23 | 9.33 | 10.63 | 9.64 | 11.96 | 10.48 | 13.29 | 13.29 | 13.41 | 13.41 | 13.84 | 13.84 | 14.89 | 14.89 |
| | | KW | 3.63 | 3.63 | 3.80 | 3.80 | 3.98 | 3.98 | 4.10 | 4.10 | 4.15 | 4.15 | 4.33 | 4.33 | 4.50 | 4.50 | 4.36 | 4.36 | 4.42 | 4.42 | 4.67 | 4.67 |
| | 755 | Cap (kW) | 6.43 | 5.95 | 7.67 | 7.06 | 8.90 | 8.17 | 9.77 | 8.91 | 10.14 | 8.20 | 11.38 | 9.97 | 12.39 | 12.39 | 13.68 | 13.68 | 14.03 | 14.03 | 14.92 | 14.92 |
| 27 | | KW | 3.28 | 3.28 | 3.50 | 3.50 | 3.73 | 3.73 | 3.88 | 3.88 | 3.95 | 3.95 | 4.17 | 4.17 | 4.18 | 4.18 | 4.41 | 4.41 | 4.49 | 4.49 | 4.67 | 4.67 |
| | 850 | Cap (kW) | 7.94 | 7.34 | 8.96 | 8.24 | 9.98 | 9.16 | 10.69 | 9.75 | 10.99 | 9.97 | 12.01 | 10.53 | 12.82 | 12.82 | 13.93 | 13.93 | 14.23 | 14.23 | 14.91 | 14.91 |
| | | KW | 3.83 | 3.83 | 3.97 | 3.97 | 4.11 | 4.11 | 4.21 | 4.21 | 4.26 | 4.26 | 4.40 | 4.40 | 4.38 | 4.38 | 4.58 | 4.58 | 4.64 | 4.64 | 4.87 | 4.87 |
| 27 | 661 | Cap (kW) | 1.57 | 1.46 | 3.58 | 3.30 | 5.59 | 5.19 | 7.00 | 6.36 | 7.60 | 6.89 | 9.61 | 8.42 | 11.62 | 11.62 | 13.03 | 13.03 | 13.63 | 13.63 | 15.64 | 15.64 |
| | | KW | 4.04 | 4.04 | 4.20 | 4.20 | 4.37 | 4.37 | 4.49 | 4.49 | 4.54 | 4.54 | 4.70 | 4.70 | 4.87 | 4.87 | 4.72 | 4.72 | 4.83 | 4.83 | 5.00 | 5.00 |
| | 755 | Cap (kW) | 3.02 | 2.79 | 5.07 | 4.86 | 7.12 | 6.59 | 8.55 | 7.79 | 9.16 | 6.31 | 11.21 | 9.82 | 13.26 | 13.26 | 13.44 | 13.44 | 14.10 | 14.10 | 15.73 | 15.73 |
| 850 | | KW | 4.09 | 4.09 | 4.31 | 4.31 | 4.53 | 4.53 | 4.68 | 4.68 | 4.75 | 4.75 | 4.96 | 4.96 | 5.18 | 5.18 | 5.34 | 5.34 | 4.96 | 4.96 | 5.18 | 5.18 |
| | 1400 | Cap (kW) | 6.81 | 6.30 | 8.20 | 7.54 | 9.58 | 8.80 | 10.55 | 9.62 | 10.97 | 9.95 | 12.36 | 10.83 | 13.75 | 13.75 | 13.85 | 13.85 | 14.35 | 14.35 | 15.39 | 15.39 |
| | | KW | 4.85 | 4.85 | 4.92 | 4.92 | 4.68 | 4.68 | 4.80 | 4.80 | 4.85 | 4.85 | 5.02 | 5.02 | 5.18 | 5.18 | 5.04 | 5.04 | 5.11 | 5.11 | 5.34 | 5.34 |

See Legend and Notes following.

PERFORMANCE DATA (CONT)

LEGEND

BF— Bypass Factor
 edb— Entering Dry—Bulb
 Ewb— Entering Wet—Bulb
 kW — Total Unit Power Input
 SHC— Sensible Heat Capacity (1000 Btuh)
 TC — Total Capacity (1000 Btuh) (net)

COOLING NOTES:

1. Ratings are net; they account for the effects of the evaporator—fan motor power and heat.
2. Direct interpolation is permissible. Do not extrapolate.
3. The following formulas may be used:

$$t_{\text{fdb}} = t_{\text{edb}} - \frac{\text{sensible capacity (Btuh)}}{1.10 \times \text{CFM}}$$

t_{fwb} = wet bulb temperature corresponding to enthalpy of air leaving evaporator coil (h_{fwb}).

$$h_{\text{fwb}} = h_{\text{ewb}} - \frac{\text{total capacity (Btuh)}}{4.5 \times \text{CFM}}$$

Where h_{ewb} is enthalpy of air entering indoor coil.

SHC is based on 80°F Edb air temperature through Evaporator coil.

Below 80°F Edb, subtract (Correction Factor x CFM) from SHC.

Above 80°F Edb, add (Correction Factor x CFM) to SHC. Correction Factor = $1.10 \times (1 - \text{BF}) \times (\text{Edb} - 80)$

$$C_{\text{fdb}} = C_{\text{edb}} - \frac{\text{SHC}_{\text{ kW}} \times 1000}{1.23 \times \text{L/s}}$$

Leaving wet bulb = wet bulb temperature corresponding to enthalpy of air leaving coil (h_{fwb}).

$$h_{\text{fwb}} = h_{\text{ewb}} - \frac{\text{TC}_{\text{ kW}} \times 1000}{1.20 \times \text{L/s}}$$

Where h_{ewb} is enthalpy of air entering indoor coil.

SHC is based on 26.7°C db temperature of air entering the unit. At any other temperature, correct the SHC read from the table of cooling capacities as follows:

Corrected $\text{SHC}_{\text{ kW}} = \text{SHC} + [1.23 \times 10^{-3} \times (1 - \text{BF}) \times (\text{C}_{\text{db}} - 26.7)] \times \text{L/s}$

Above 26.7°C, SHC correction is positive; add it to SHC. Below 26.7°C, SHC correction is negative; subtract it from SHC.

PERFORMANCE DATA (CONT)

Electric Heater Multiplication Factors

| HEATER kW RATING | VOLTAGE DISTRIBUTION V/3/60 | MULTIPLICATION FACTOR |
|------------------|-----------------------------|-----------------------|
| 400 | 380 | .90 |
| | 400 | 1.00 |
| | 415 | 1.08 |
| | 420 | 1.10 |

Example: 12.1 kW (at 400 v) heater on 380 v
 = 12.1 (.90 multiplication factor)
 = 10.9 kW capacity at 380 v

NOTE: Heater kW rating is voltage as marked on the base unit nameplate. Voltage distribution is the design power supply at installation site.

Wet Coil Air Delivery Horizontal and Downflow Discharge* PH4E (50 Hz) 24-48

| ENGLISH | | | | | | | | | | | | | |
|----------|-------------|------------------------------------|------|------|------|------|------|------|------|------|------|------|------|
| 400 VOLT | | | | | | | | | | | | | |
| UNIT | MOTOR SPEED | EXTERNAL STATIC PRESSURE (IN. W.C) | | | | | | | | | | | |
| | | 0.0 | 0.1 | 0.2 | 0.3 | 0.4 | 0.5 | 0.6 | 0.7 | 0.8 | 0.9 | 1.0 | |
| PH4E24 | Low | Watts | 303 | 305 | 306 | 300 | - | - | - | - | - | - | - |
| | | Cfm | 969 | 879 | 785 | 687 | - | - | - | - | - | - | - |
| | High | Watts | - | - | - | - | 435 | 428 | 428 | 422 | - | - | - |
| | | Cfm | - | - | - | - | 963 | 833 | 758 | 676 | - | - | - |
| PH4E30 | Low | Watts | - | 1002 | 954 | 921 | 889 | 853 | 814 | - | - | - | - |
| | | Cfm | - | 1189 | 1115 | 1041 | 971 | 903 | 833 | - | - | - | - |
| | High | Watts | - | - | - | - | - | - | - | 700 | 683 | 688 | 755 |
| | | Cfm | - | - | - | - | - | - | - | 1223 | 1142 | 1075 | 1058 |
| PH4E36 | Low | Watts | 552 | 540 | 529 | 523 | 514 | 480 | - | - | - | - | - |
| | | Cfm | 1296 | 1237 | 1167 | 1097 | 1029 | 952 | - | - | - | - | - |
| | High | Watts | - | - | - | - | - | 782 | 765 | 736 | 721 | 780 | 1002 |
| | | Cfm | - | - | - | - | - | 1467 | 1398 | 1321 | 1237 | 1165 | 1137 |
| PH4E48 | Low | Watts | 692 | 686 | 678 | 664 | 652 | 664 | 736 | - | - | - | - |
| | | Cfm | 1571 | 1509 | 1444 | 1370 | 1295 | 1240 | 1237 | - | - | - | - |
| | High | Watts | - | - | 1112 | 930 | 856 | 834 | 825 | 811 | 793 | - | - |
| | | Cfm | - | - | 1693 | 1670 | 1601 | 1521 | 1447 | 1378 | 1294 | - | - |
| SI | | | | | | | | | | | | | |
| 400 VOLT | | | | | | | | | | | | | |
| UNIT | MOTOR SPEED | EXTERNAL STATIC PRESSURE (Pa) | | | | | | | | | | | |
| | | 0 | 25 | 50 | 75 | 100 | 125 | 150 | 175 | 200 | 225 | 250 | |
| PH4E24 | Low | Watts | 303 | 305 | 303 | 300 | - | - | - | - | - | - | - |
| | | L/s | 458 | 415 | 371 | 324 | - | - | - | - | - | - | - |
| | High | Watts | - | - | - | - | 435 | 428 | 428 | 422 | - | - | - |
| | | L/s | - | - | - | - | 455 | 393 | 358 | 319 | - | - | - |
| PH4E30 | Low | Watts | - | 1002 | 954 | 921 | 889 | 853 | 814 | - | - | - | - |
| | | L/s | - | 561 | 526 | 491 | 458 | 426 | 393 | - | - | - | - |
| | High | Watts | - | - | - | - | - | - | - | 700 | 683 | 688 | 755 |
| | | L/s | - | - | - | - | - | - | - | 577 | 539 | 508 | 499 |
| PH4E36 | Low | Watts | 552 | 540 | 529 | 523 | 514 | 480 | - | - | - | - | - |
| | | L/s | 612 | 584 | 551 | 518 | 486 | 449 | - | - | - | - | - |
| | High | Watts | - | - | - | - | - | 782 | 765 | 736 | 721 | 780 | 1002 |
| | | L/s | - | - | - | - | - | 693 | 660 | 624 | 584 | 550 | 536 |
| PH4E48 | Low | Watts | 692 | 686 | 678 | 664 | 652 | 664 | 736 | - | - | - | - |
| | | L/s | 741 | 712 | 681 | 647 | 611 | 585 | 584 | - | - | - | - |
| | High | Watts | - | - | 1112 | 930 | 856 | 834 | 825 | 811 | 793 | - | - |
| | | L/s | - | - | 799 | 788 | 756 | 718 | 683 | 650 | 611 | - | - |

*Air delivery values are based on operating voltage of 400-v, wet coil, without filter or electric heater. Deduct filter and electric heater pressure drops to obtain static pressure available for ducting.

NOTES: 1. Do not operate the unit at a cooling airflow that is less than 350 cfm for each 12,000 Btuh (165 L/s for each 3.5 kW) of rated cooling capacity. Evaporator coil frosting may occur at airflow below this point.

2. Dashes indicate portions of table that are beyond the blower motor capacity or are not recommended.

Table 1 – Filter Pressure Drop (IN. W.C.) (Pa)

| FILTER SIZE in. | CFM | | | | | | | | | | | | | | | | | | |
|-----------------|------|------|------|------|------|------|------|------|------|------|------|------|------|------|------|------|------|------|------|
| | 500 | 600 | 700 | 800 | 900 | 1000 | 1100 | 1200 | 1300 | 1400 | 1500 | 1600 | 1700 | 1800 | 1900 | 2000 | 2100 | 2200 | 2300 |
| 20X20X1 | 0.05 | 0.07 | 0.08 | 0.10 | 0.12 | 0.13 | 0.14 | 0.15 | - | - | - | - | - | - | - | - | - | - | - |
| 20X24X1 | - | - | - | - | 0.09 | 0.10 | 0.11 | 0.13 | 0.14 | 0.15 | 0.16 | - | - | - | - | - | - | - | - |
| 24X30X1 | - | - | - | - | - | - | - | 0.07 | 0.08 | 0.09 | 0.10 | 0.11 | 0.12 | 0.13 | 0.14 | 0.15 | 0.16 | 0.17 | 0.18 |
| FILTER SIZE mm | L/s | | | | | | | | | | | | | | | | | | |
| | 236 | 283 | 330 | 378 | 425 | 472 | 519 | 566 | 614 | 661 | 707 | 755 | 802 | 850 | 896 | 944 | 991 | 1038 | 1085 |
| 508X508X25 | 12.4 | 17.4 | 19.9 | 24.9 | 29.9 | 32.3 | 34.8 | 37.3 | - | - | - | - | - | - | - | - | - | - | - |
| 508X610x25 | - | - | - | - | 22.4 | 24.9 | 27.4 | 32.3 | 34.8 | 37.4 | 39.9 | - | - | - | - | - | - | - | - |
| 610X762x25 | - | - | - | - | - | - | - | 17.4 | 19.9 | 22.4 | 24.9 | 27.4 | 29.9 | 32.3 | 34.8 | 37.3 | 39.8 | 42.3 | 44.6 |

Table 2 – Accessory Electric Heat Pressure Drop (IN. W.C.) (Pa)

| HEATER kW | CFM | | | | | | | | |
|------------|-------|-------|-------|-------|-------|-------|-------|-------|-------|
| | 600 | 800 | 1000 | 1200 | 1400 | 1600 | 1800 | 2000 | 2200 |
| 6.5 – 17.4 | 0.030 | 0.033 | 0.037 | 0.042 | 0.047 | 0.052 | 0.060 | 0.067 | 0.075 |
| | L/s | | | | | | | | |
| | 283 | 378 | 472 | 569 | 661 | 755 | 850 | 944 | 1038 |
| | 7.5 | 8.2 | 9.2 | 10.4 | 11.7 | 12.9 | 14.9 | 16.7 | 18.7 |

| SUPERHEAT CHARGING TABLE (SUPERHEAT °C AT LOW-SIDE SERVICE PORT) | | | | | | | | | | | | | | REQUIRED SUCTION TUBE TEMPERATURE °C (MEASURED AT LOW-SIDE SERVICE PORT) | | | | | | | | | | | |
|---|-------------------------------|-----|-----|-----|------|------|------|------|------|------|------|------|------|---|--|------------|------|------|------|------|------|------|------|------|------|
| OUTDOOR TEMP. (°C) | ENTERING EVAPORATOR AIR °C WB | | | | | | | | | | | | | SUPERHEAT | SUCTION PRESSURE AT SERVICE PORT (kPa) | | | | | | | | | | |
| | 10 | 11 | 12 | 13 | 14 | 15 | 16 | 17 | 18 | 19 | 20 | 21 | 22 | 23 | 24 | TEMP. (°C) | 743 | 774 | 805 | 836 | 869 | 902 | 957 | 971 | 1005 |
| 13 | 5.0 | 6.7 | 7.8 | 9.4 | 11.1 | 11.9 | 12.8 | 14.4 | 16.1 | 17.8 | 19.4 | 20.6 | 22.2 | 23.3 | 25.0 | 0 | 1.7 | 2.8 | 3.9 | 5.0 | 6.1 | 7.2 | 8.3 | 9.4 | 10.6 |
| 16 | 3.9 | 5.6 | 6.7 | 8.3 | 10.0 | 10.8 | 11.7 | 13.3 | 15.0 | 16.7 | 18.3 | 20.0 | 21.1 | 22.2 | 23.9 | 1 | 2.8 | 3.9 | 5.0 | 6.1 | 7.2 | 8.3 | 9.4 | 10.6 | 11.7 |
| 18 | - | 3.3 | 5.6 | 7.2 | 8.9 | 9.7 | 10.6 | 11.7 | 13.3 | 15.0 | 16.7 | 18.3 | 20.0 | 21.1 | 22.8 | 2 | 3.9 | 5.0 | 6.1 | 7.2 | 8.3 | 9.4 | 10.6 | 11.7 | 12.8 |
| 21 | - | - | 3.9 | 5.6 | 7.2 | 8.1 | 8.9 | 10.6 | 11.7 | 13.3 | 15.0 | 16.7 | 18.3 | 20.0 | 21.7 | 3 | 5.0 | 6.1 | 7.2 | 8.3 | 9.4 | 10.6 | 11.7 | 12.8 | 13.9 |
| 24 | - | - | - | 3.3 | 5.0 | 5.8 | 6.7 | 8.3 | 10.0 | 11.7 | 7.8 | 15.6 | 17.2 | 18.9 | 20.6 | 4 | 6.1 | 7.2 | 8.3 | 9.4 | 10.6 | 11.7 | 12.8 | 13.9 | 15.0 |
| 27 | - | - | - | - | 2.8 | 3.6 | 4.4 | 6.7 | 8.3 | 10.0 | 11.7 | 13.9 | 15.6 | 17.2 | 19.4 | 6 | 7.2 | 8.3 | 9.4 | 10.6 | 11.7 | 12.8 | 13.9 | 15.0 | 16.1 |
| 29 | - | - | - | - | - | - | - | 4.4 | 6.1 | 8.3 | 10.6 | 12.2 | 14.4 | 16.7 | 18.3 | 7 | 8.3 | 9.4 | 10.6 | 11.7 | 12.8 | 13.9 | 15.0 | 16.1 | 17.2 |
| 32 | - | - | - | - | - | - | - | 2.8 | 5.0 | 7.2 | 8.9 | 11.1 | 13.3 | 15.0 | 17.2 | 8 | 9.4 | 10.6 | 11.7 | 12.8 | 13.9 | 15.0 | 16.1 | 17.2 | 18.3 |
| 35 | - | - | - | - | - | - | - | - | 3.3 | 5.6 | 7.8 | 10.0 | 12.2 | 13.9 | 16.1 | 9 | 10.6 | 11.7 | 12.8 | 13.9 | 15.0 | 16.1 | 17.2 | 18.3 | 19.4 |
| 38 | - | - | - | - | - | - | - | - | - | 4.4 | 6.7 | 8.3 | 11.1 | 12.8 | 15.0 | 10 | 11.7 | 12.8 | 13.9 | 15.0 | 16.1 | 17.2 | 18.3 | 19.4 | 20.6 |
| 41 | - | - | - | - | - | - | - | - | - | 2.8 | 5.0 | 7.2 | 9.4 | 12.2 | 14.4 | 11 | 12.8 | 13.9 | 15.0 | 16.1 | 17.2 | 18.3 | 19.4 | 20.6 | 21.7 |
| 43 | - | - | - | - | - | - | - | - | - | - | 3.3 | 6.1 | 8.3 | 11.1 | 13.9 | 12 | 13.9 | 15.0 | 16.1 | 17.2 | 18.3 | 19.4 | 20.6 | 21.7 | 22.8 |
| 46 | - | - | - | - | - | - | - | - | - | - | - | 4.4 | 7.8 | 10.0 | 12.8 | 13 | 15.0 | 16.1 | 17.2 | 18.3 | 19.4 | 20.6 | 21.7 | 22.8 | 23.9 |
| | | | | | | | | | | | | | | | | 14 | 16.1 | 17.2 | 18.3 | 19.4 | 20.6 | 21.7 | 22.8 | 23.9 | 25.0 |
| | | | | | | | | | | | | | | | | 16 | 17.2 | 18.3 | 19.4 | 20.6 | 21.7 | 22.8 | 23.9 | 25.0 | 26.1 |
| | | | | | | | | | | | | | | | | 17 | 18.3 | 19.4 | 20.6 | 21.7 | 22.8 | 23.9 | 25.0 | 26.1 | 27.2 |
| | | | | | | | | | | | | | | | | 18 | 19.4 | 20.6 | 21.7 | 22.8 | 23.9 | 25.0 | 26.1 | 27.2 | 28.3 |
| | | | | | | | | | | | | | | | | 19 | 20.6 | 21.7 | 22.8 | 23.9 | 25.0 | 26.1 | 27.2 | 28.3 | 29.4 |
| | | | | | | | | | | | | | | | | 20 | 21.7 | 22.8 | 23.9 | 25.0 | 26.1 | 27.2 | 28.3 | 29.4 | 30.6 |
| | | | | | | | | | | | | | | | | 21 | 22.8 | 23.9 | 25.0 | 26.1 | 27.2 | 28.3 | 29.4 | 30.6 | 31.7 |
| | | | | | | | | | | | | | | | | 22 | 23.9 | 25.0 | 26.1 | 27.2 | 28.3 | 29.4 | 30.6 | 31.7 | 32.8 |

50E5500443 - 2.0

A09336

Fig. 1 - Cooling Charging Chart

TYPICAL PIPING AND WIRING

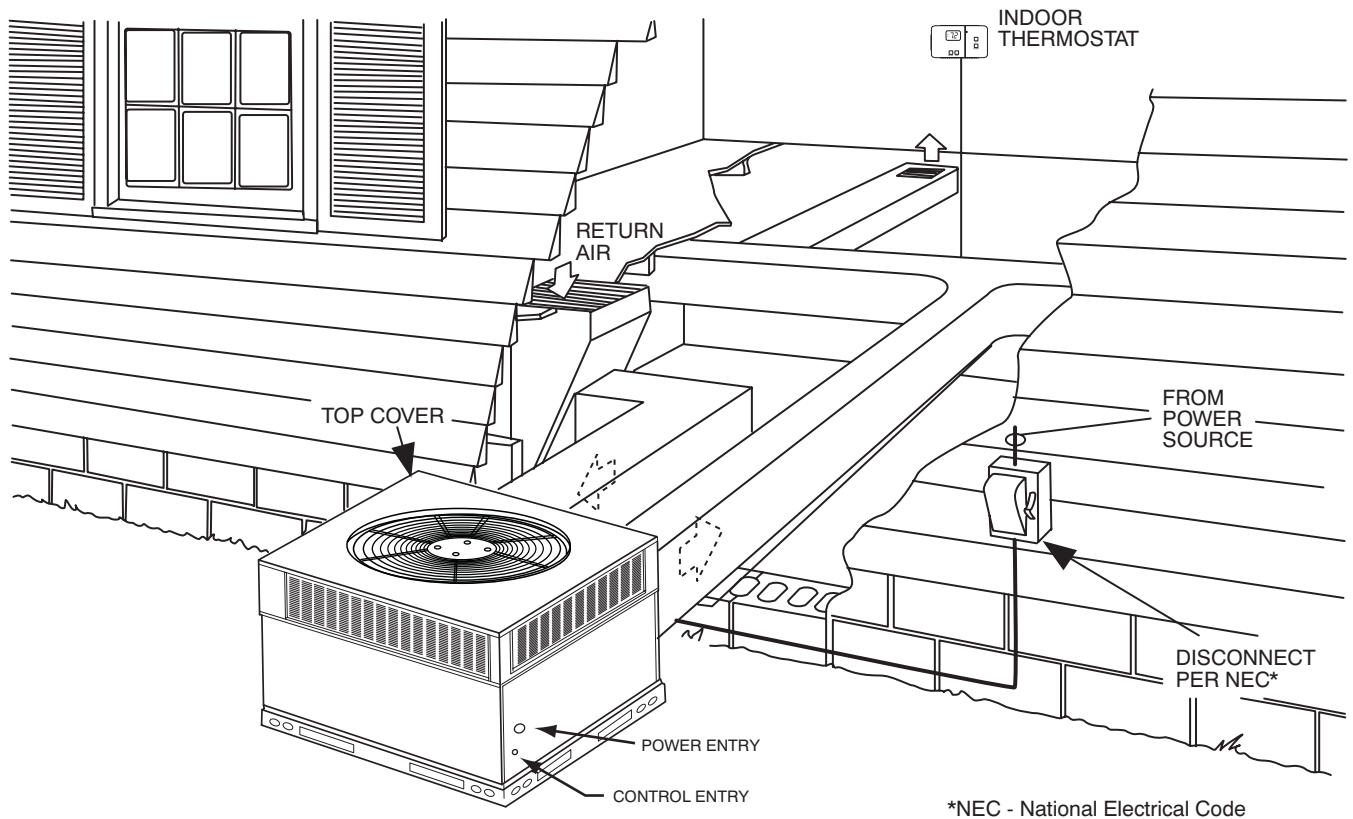
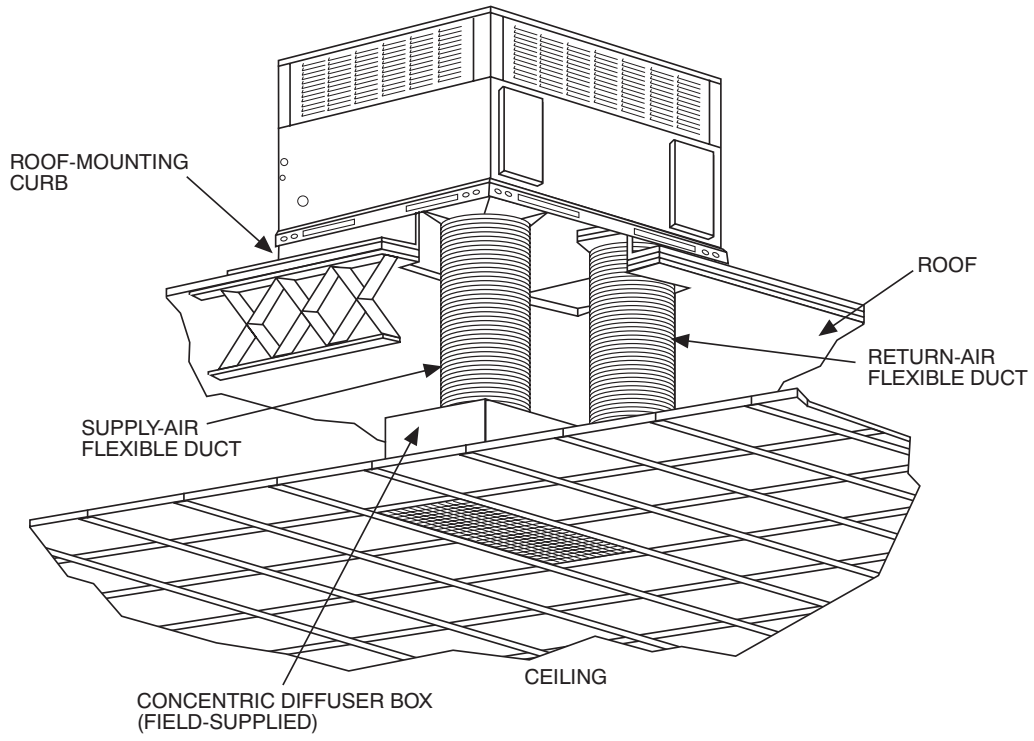

BALANCE POINT WORKSHEET - METRIC

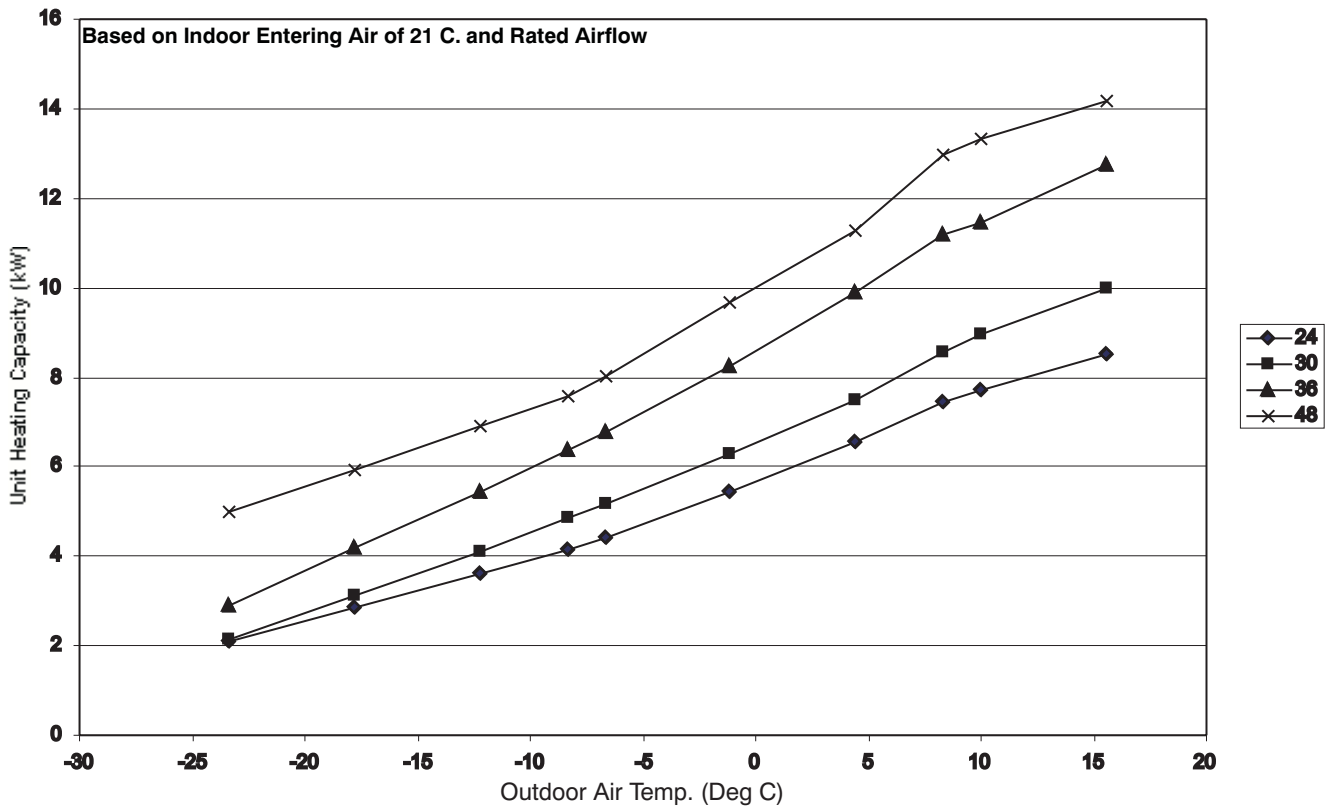

A09571

BALANCE POINT WORKSHEET - ENGLISH

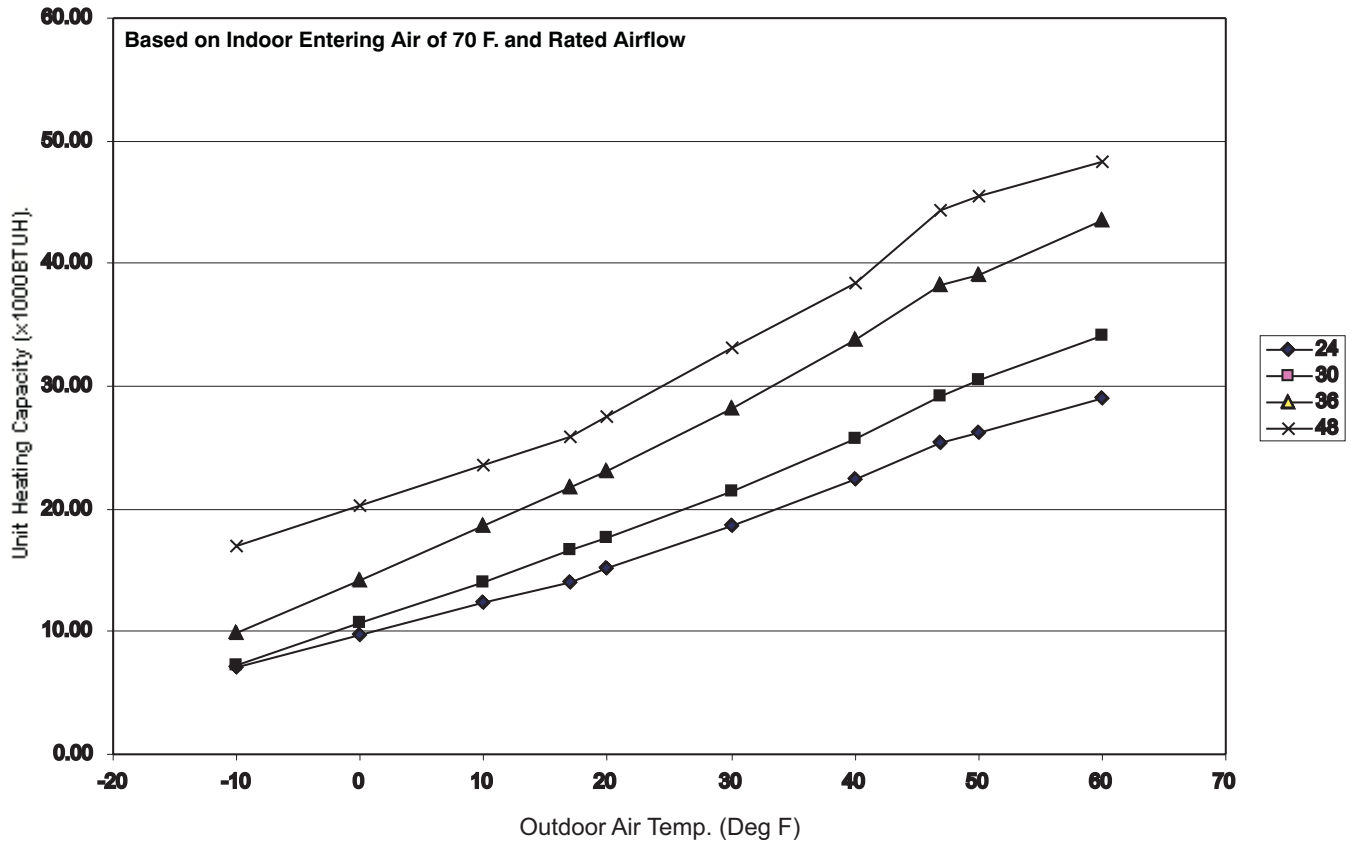

A09572

ELECTRICAL DATA

| UNIT | NOMINAL | VOLTAGE RANGE | | COMPRESSOR | | OFM | IFM | ELECTRIC HEAT | | POWER SUPPLY | |
|--------|----------|---------------|-----|------------|------|-----|-----|---------------|------|--------------|------|
| | | MIN | MAX | RLA | LRA | FLA | FLA | NOMINAL kW | FLA | MCA | MOCP |
| PH4E24 | 400-3-50 | 380 | 420 | 4.5 | 32.0 | 0.8 | 1.1 | - | - | 7.5 | 15 |
| | | | | | | | | 6.5 | 9.4 | 19.3 | 20 |
| | | | | | | | | 8.7 | 12.6 | 23.3 | 25 |
| PH4E30 | 400-3-50 | 380 | 420 | 5.2 | 35.0 | 0.8 | 1.7 | - | - | 9.0 | 15 |
| | | | | | | | | 6.5 | 9.4 | 20.8 | 25 |
| | | | | | | | | 8.7 | 12.6 | 24.8 | 25 |
| PH4E36 | 400-3-50 | 380 | 420 | 6.5 | 46.0 | 0.8 | 2.0 | 13.0 | 18.8 | 32.5 | 35 |
| | | | | | | | | - | - | 10.9 | 15 |
| | | | | | | | | 6.5 | 9.4 | 22.7 | 25 |
| PH4E48 | 400-3-50 | 380 | 420 | 6.7 | 50.0 | 1.3 | 3.9 | 8.7 | 12.6 | 26.7 | 30 |
| | | | | | | | | 13.0 | 18.8 | 34.4 | 35 |
| | | | | | | | | - | - | 13.6 | 20 |
| PH4E48 | 400-3-50 | 380 | 420 | 6.7 | 50.0 | 1.3 | 3.9 | 6.5 | 9.4 | 25.3 | 30 |
| | | | | | | | | 8.7 | 12.6 | 29.3 | 30 |
| | | | | | | | | 13.0 | 18.8 | 37.1 | 40 |
| | | | | | | | | 17.4 | 25.1 | 45.0 | 45 |

LEGEND

FLA – Full Load Amps
 LRA – Locked Rotor Amps
 MCA – Minimum Circuit Amps
 MOCP – Maximum Overcurrent Protection
 RLA – Rated Load Amps

NOTES:

- In compliance with NEC (National Electrical Code) requirements for multimotor and combination load equipment (refer to NEC Articles 430 and 440), the overcurrent protective device for the unit shall be Power Supply fuse. The CGA (Canadian Gas Association) units may be fuse or circuit breaker.
- Minimum wire size is based on 60 C copper wire. If other than 60 C wire is used, or if length exceeds wire length in table, determine size from NEC.

3. Unbalanced 3-Phase Supply Voltage

Never operate a motor where a phase imbalance in supply voltage is greater than 2%. Use the following formula to determine the percentage of voltage imbalance.

$$\% \text{ Voltage imbalance} = 100 \times \frac{\text{max voltage deviation from average voltage}}{\text{average voltage}}$$

Determine maximum deviation from average voltage.

(AB) 397 – 393 = 4v

(BC) 403 – 397 = 6v

(AC) 397 – 396 = 1v

Maximum deviation is 6v.

Determine percent of voltage imbalance.

$$\% \text{ Voltage imbalance} = 100 \times \frac{6}{397}$$

$$= 1.5\%$$

This amount of phase imbalance is satisfactory as it is below the maximum allowable 2%.

IMPORTANT: If the supply voltage phase imbalance is more than 2%, contact your local electric utility company immediately.

TYPICAL WIRING SCHEMATIC 400-3-50

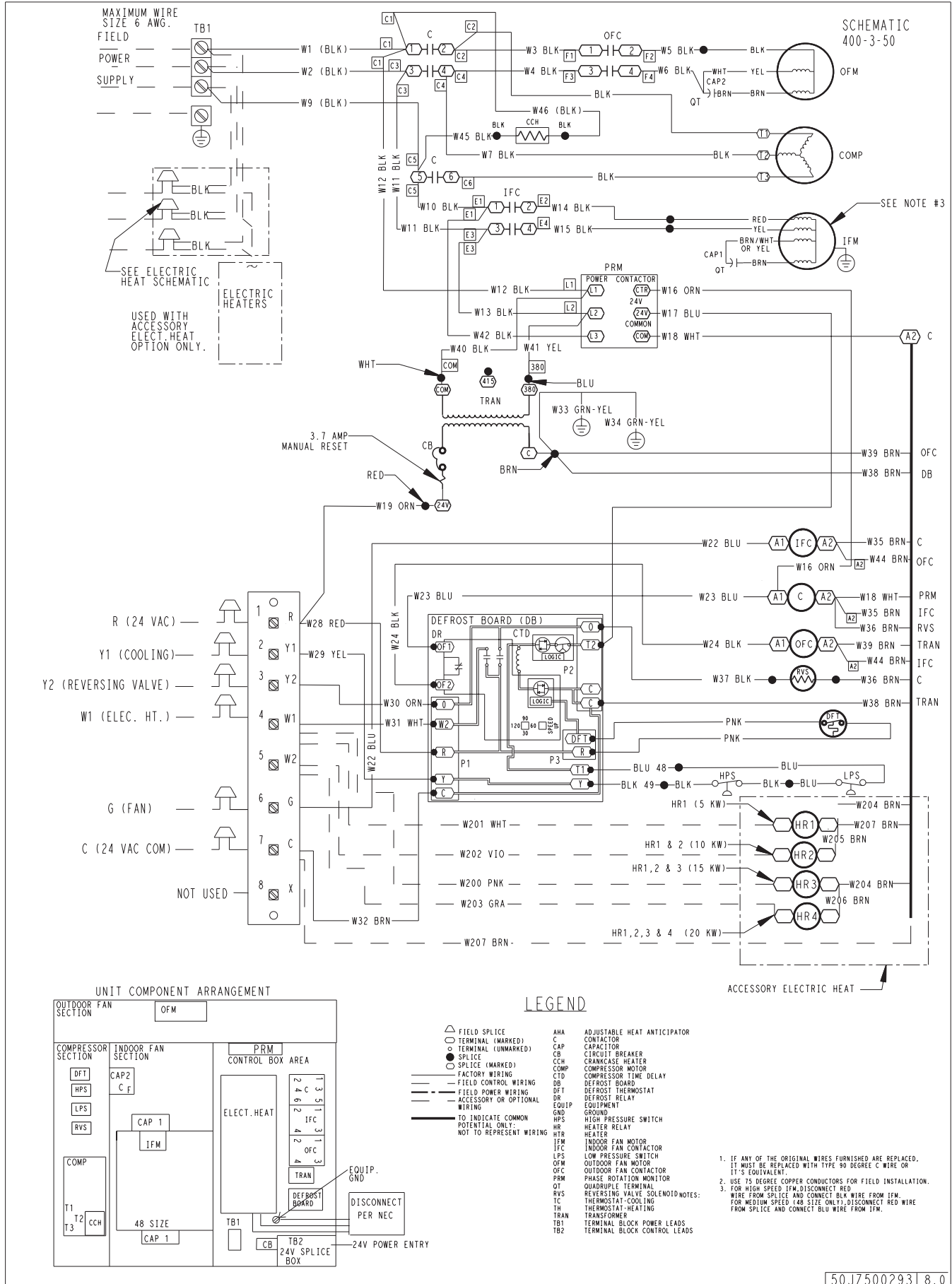

50JZ500293 | 8.0

A09504

APPLICATION DATA

Condensate trap — A 2-in. (51 mm) condensate trap must be field supplied.

Ductwork — Secure downflow discharge ductwork to roof curb. For horizontal discharge applications, attach ductwork to unit with flanges.

To convert a unit to downflow discharge — Units are equipped with factory sealed covers in the downflow openings.

Maximum cooling airflow — To minimize the possibility of condensate blow-off from the evaporator, airflow through the units should not exceed 450 cfm per ton (60 l/s per kW).

Minimum cooling airflow — Minimum cooling airflow is 350 cfm per ton (46.8 l/s per kW).

Minimum ambient cooling operation temperature — All standard units have a minimum ambient operating temperature of 40°F (4°C). With accessory low ambient temperature kit, units can operate at temperatures down to 0°F (-17°C).

CONTROLS

Operating sequence

Cooling — When the system thermostat calls for cooling, 24 V is supplied to the “Y” and “G” terminals of the thermostat. This completes the circuit to the contactor coil (C) and indoor (evaporator) fan relay (IFR). The normally open contacts of energized C close and complete the circuit through compressor motor (COMP) to outdoor (condenser) fan motor (OFM). Both motors start instantly. The set of normally open contacts of energized IFR close and complete the circuit through IFM. The IFM starts instantly.

On the loss of the thermostat call for cooling, 24 V is removed from both the “Y” and “G” terminals (provided the fan switch is in the “AUTO” position) de-energizing the compressor contactor and opening the contacts supplying power to compressor/OFM and IFM. If the thermostat fan selector switch is in the “ON” position, the IFM will run continuously.

NOTE: The PH4E unit is equipped with a defrost board with a built-in Time Guard® II device: Once the compressor has started and then stopped, it cannot be restarted again until 5 minutes have elapsed.

Heating — If accessory electric heaters are installed, on a call for heat, circuit R-W is made through the thermostat contacts. Circuit R-G is made which energizes the IFR. If the heaters are staged, then the thermostat closes a second set of contacts (W2) when second stage is required. When thermostat is satisfied, contacts open, deenergizing the heater relay and the IFR.

GUIDE SPECIFICATIONS

Single-Packaged Heat Pump System

Constant Volume Application

HVAC Guide Specifications

Size Range: **2 to 4 Tons, Nominal Cooling**

Model Number: PH4E

Part 1 — General

SYSTEM DESCRIPTION

Outdoor rooftop mounted or ground mounted, electric cooling unit utilizing a hermetic scroll compressor for cooling duty. Unit shall discharge supply air vertically or horizontally as shown on contract drawings. Condenser fan/coil section shall have a draw-thru design with vertical discharge for minimum sound levels.

QUALITY ASSURANCE

B. Unit shall be tested in accordance with ARI Standards 210/240 and 270.

C. Unit shall be designed in accordance with UL Standard 1995 and EN 60335-1.

D. Roof curb shall be designed to conform to NRCA Standards.

E. Insulation and adhesives shall meet NFPA 90A requirements for flame spread and smoke generation.

F. Cabinet insulation shall meet ASHRAE Standard 62P.

DELIVERY, STORAGE AND HANDLING

Unit shall be stored and handled per manufacturer's recommendations.

Part 2 — Products

EQUIPMENT

A. General:

Factory-assembled, single-piece, heating and cooling unit. Contained within the enclosure shall be all factory wiring, piping, controls, refrigerant charge with R-410A refrigerant, and special features required prior to field start-up.

B. Unit Cabinet:

1. Unit cabinet shall be constructed of phosphated, zinc-coated, pre-painted steel capable of with-standing 500 hours in salt spray.
2. Normal service shall be through a single removable cabinet panel.
3. The unit shall be constructed on a rust resistant unit base that has an externally trapped, integrated sloped drain.
4. Evaporator fan compartment top surface shall be insulated with a minimum 1/2-in. (12.7 mm) thick, flexible fiberglass insulation, coated on the air side and retained by adhesive and mechanical means. The evaporator wall sections will be insulated with a minimum semi-rigid foil-faced board capable of being wiped clean. Aluminum foil-faced fiberglass insulation shall be used in the entire indoor air cavity section.
5. Unit shall have a field-supplied condensate trap.

C. Fans:

1. The evaporator fan shall be direct-drive multi-speed motor and control, as shown on equipment drawings.
2. Fan wheel shall be made from steel, be double-inlet type with forward curved blades with corrosion resistant finish. Fan wheel shall be dynamically balanced.
3. Condenser fan shall be direct drive propeller type with aluminum blades riveted to corrosion resistant steel spiders, be dynamically balanced, and discharge air vertically.

D. Compressor:

1. Fully hermetic compressors with factory-installed vibration isolation.
2. Scroll compressors shall be standard on all units.

E. Coils:

Evaporator and condenser coils shall have aluminum plate fins mechanically bonded to seamless copper tubes with all joints brazed. Tube sheet openings shall be belled to prevent tube wear.

F. Refrigerant Components:

Refrigerant expansion device shall be of the fixed orifice type.

G. Filters:

Filter section shall consist of field-installed, throwaway, 1-in. (25 mm) thick fiberglass filters of commercially available sizes.

H. Controls and Safeties:

1. Unit controls shall be complete with a self-contained low voltage control circuit.
2. Compressors shall incorporate a solid-state compressor protector that provides reset capability.

I. Operating Characteristics:

1. Unit shall be capable of starting and running at 125°F (51°C) ambient outdoor temperature (except 48 size shall be capable of starting and running at 115° F [46°C]).
2. Compressor with standard controls shall be capable of operation down to 40°F (4°C) ambient outdoor temperature.

J. Electrical Requirements:

All unit power wiring shall enter the unit cabinet at a single location.

K. Motors:

1. Compressor motors shall be of the refrigerant-cooled type with line-break thermal and current overload protection.
2. All fan motors shall have permanently lubricated bearings, and inherent, automatic reset, thermal overload protection.

L. Special Features:

1. Thermostat:
To provide for one-stage heating and cooling in addition manual or automatic changeover and indoor fan control.
2. Crankcase Heater:
Shall provide anti-flooded start protection for low-load cooling applications.
3. Electric Heaters:
 - a. Electric heater shall be available as a field-installed option.
 - b. Heater elements shall be open wire type, adequately supported and insulated with ceramic bushings.
 - c. Electric heater packages must provide single point power connection capability.

GUIDE SPECIFICATIONS (CONT)

4. Filter Rack Kit:
Shall provide filter mounting for downflow applications.
5. Flat Roof Curb:
Curbs shall have seal strip and a wood nailer for flashing and shall be installed per manufacturer's instructions.
6. Low Ambient Package:
Shall consist of a solid-state control and condenser coil temperature sensor for controlling condenser-fan motor operation, which shall allow unit to operate down to 0°F (-17.7°C) outdoor ambient temperature when properly installed.
7. Manual Outdoor Air Damper:
Package shall consist of damper, birdscreen, and rainhood which can be preset to admit outdoor air for year-round ventilation.
8. Square-To-Round Duct Transitions (24-48 size):
Shall have the ability to convert the supply and return openings from rectangular to round.
9. Time Guard II
Automatically prevents the compressor from restarting for at least 4 minutes and 45 seconds after shutdown of the compressor.